



MODEL NUMBERS:

15B045, 15B070, 15B096,
15B120, 15B145, 15B175,
15B195, 15B245, 15B295

15B SERIES

Cast Iron Gas Fired Boilers For Forced Hot Water

INSTALLATION, OPERATION & MAINTENANCE MANUAL

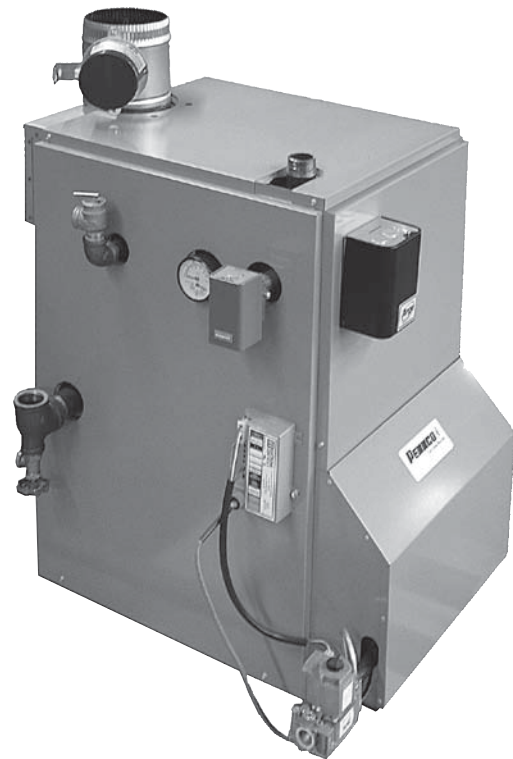

An ISO 9001-2000 Certified Company



PENNCO BOILERS

85 Middle Rd.

Dunkirk, NY 14048

www.ecrinternational.com

P/N 1305026, Rev. D [04/09]

INSTALLATION MANUAL AND OPERATING INSTRUCTIONS

TABLE OF CONTENTS

| | |
|--|----|
| Ratings & Data - Natural Gas & Propane Gas ... | 4 |
| Installation Procedure..... | 5 |
| Ventilation & Combustion Air | 6 |
| Connecting Supply & Return Piping..... | 8 |
| Vent Installation | 12 |
| Vent System Modification | 12 |
| Vent Damper Installation & Instructions..... | 13 |
| Connecting Gas Service..... | 14 |
| Electrical Section..... | 14 |
| Lighting Instructions..... | 19 |
| Normal Sequence of Operation..... | 21 |
| General Instructions | 21 |
| Checking Gas Input Rate To Boiler | 23 |
| Boiler Exploded View..... | 24 |
| Conversion Kits | 30 |

KEEP THIS MANUAL NEAR BOILER
RETAIN FOR FUTURE REFERENCE

SAFETY SYMBOLS & WARNINGS

The following defined symbols are used throughout this manual to notify the reader of potential hazards of varying risk levels.

DANGER

Indicates an *imminently* hazardous situation
Which, if not avoided, *will* result in death, serious
injury or substantial property damage.

WARNING

Indicates a potentially hazardous situation which,
if not avoided, could result in death, serious injury
or substantial property damage.

CAUTION

Indicates a potentially hazardous situation which,
if not avoided, could result in minor or moderate
injury or property damage.

IMPORTANT: Read the following instructions **COMPLETELY** before installing!!

WARNING

1. Keep boiler area clear and free from combustible materials, gasoline and other flammable vapors and liquids.
2. **DO NOT** obstruct air openings to the boiler room.
3. Modification, substitution or elimination of factory equipped, supplied or specified components may result in property damage, personal injury or the loss of life.
4. **TO THE OWNER** - Installation and service of this boiler must be performed by a qualified installer.
5. **TO THE INSTALLER** - Leave all instructions with the boiler for future reference.
6. When this product is installed in the Commonwealth of Massachusetts the installation must be performed by a Licensed Plumber or Licensed Gas Fitter.

WARNING

All installations of boilers and venting should be done only by a qualified expert and in accordance with the appropriate manual. Installing or venting a boiler or any other gas appliance with improper methods or materials may result in serious injury or death due to fire or to asphyxiation from poisonous gases such as carbon monoxide which is odorless and invisible.



C.S.A. Certified
For Natural Gas Or Propane



Tested For 100 LBS.
ASME
Working Pressure



RATINGS & DATA - NATURAL GAS & PROPANE GAS

| Model No. | A.G.A. Input Btu/Hr. ⁽¹⁾ | Heating Capacity Btu/Hr. ⁽¹⁾ | I=B=R NetOutput Btu/Hr. ^{(1)**} | NetRating Sq. Ft. HW @ 170° ⁽²⁾ | No. Of Burners | Recommended Air Cushion Tank ⁽³⁾ | Water Content (Gals.) | AFUE Elect. Ign. | AFUE Stdg. Pilot |
|-----------|-------------------------------------|---|--|--|----------------|---|-----------------------|------------------|------------------|
| 15B045 | 45,000 | 37,000 | 32,000 | 243 | 1 | 15 | 2.4 | 82% | 80% |
| 15B070 | 70,000 | 57,000 | 50,000 | 365 | 2 | 15 | 4.0 | 82% | 80% |
| 15B096 | 96,000 | 79,000 | 69,000 | 481 | 2 | 30 | 4.0 | 82% | 80% |
| 15B120 | 120,000 | 98,000 | 85,000 | 603 | 3 | 30 | 5.6 | 82% | 80% |
| 15B145 | 145,000 | 119,000 | 103,000 | 719 | 3 | 30 | 5.6 | 82% | 80% |
| 15B175 | 175,000 | 141,000 | 123,000 | 829 | 4 | 30 | 7.2 | 80.5% | 80% |
| 15B195 | 195,000 | 157,000 | 137,000 | 957 | 4 | 30 | 7.2 | 80.5% | 80% |
| 15B245 | 245,000 | 197,000 | 171,000 | 1,189 | 5 | 30 | 8.8 | 80.5% | 80% |
| 15B295 | 295,000 | 237,000 | 206,000 | 1,368 | 6 | 60 | 10.4 | 80.5% | 80% |

EXPLANATORY NOTES

--All boilers are design certified for installation on noncombustible floor.

--For installation on combustible floors use combustible floor kit.

--Recommended chimney height 20 feet. In special cases where conditions permit, chimney height may be reduced to 10 feet. Refer to the latest revision of NFGC part 11.

--Electric service to be 120 Volts, 15 Amps, 60 Hz.

--The MEA number for the this boiler is 39-86-E Vol VIII.

(1) For elevations above 2000 feet, ratings should be reduced at a rate of 4% for each 1000 feet above sea level.

(2) Base on 170° temperature in radiators.

(3) Tank sized for non-ferrous baseboard or radiant panel systems. Increase size for cast iron baseboard and radiation.

--Net I=B=R ratings include 15% allowance for normal piping and pick-up load. Manufacturer should be consulted on installations having other than normal piping and pick-up requirements.

** For equivalent square feet of radiation, divide I=B=R output by 150.

STANDARD EQUIPMENT: Boiler Jacket, Cast Iron Boiler Battery, High Limit Control, Vent Damper Relay, Theraltimeter Gauge, Circulator With Return Piping To Boiler, Main Gas Burners, Combination 24 Volt Gas Control (Includes Automatic Gas Valve, Gas Pressure Regulator, Automatic Pilot, Safety Shutoff, Pilot Flow Adjustment, Pilot Filter), A.S.M.E. Relief Valve, Drain Cock, Spill Switch, Rollout Switch, Automatic Vent Damper. Not Shown Are: Wiring Harness, Thermocouple, Non-linting Safety Pilot.

OPTIONAL EQUIPMENT: Intermittent Electric Ignition Pilot System.

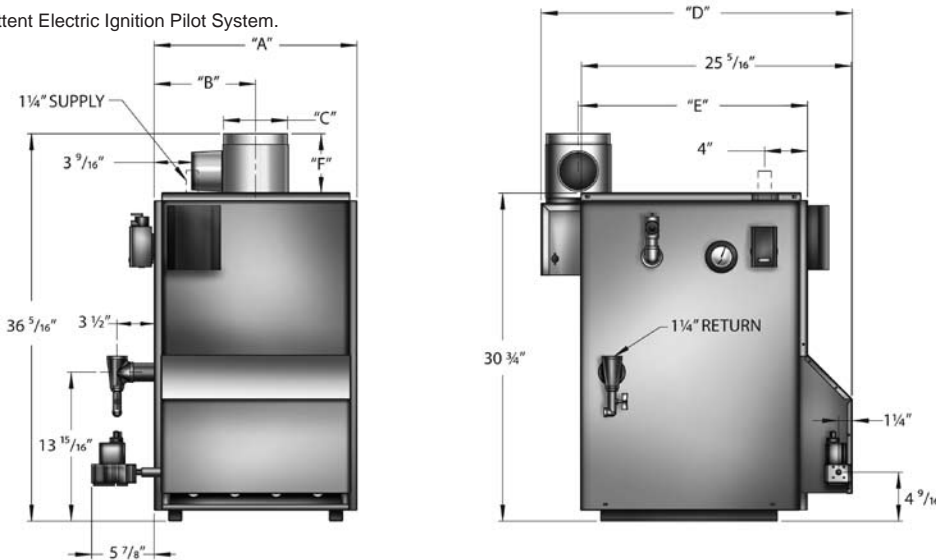

| Model No. | Natural Gas Inlet* | Dimensions (Inches) | | | | | | Pump Size Supply & Return Tappings |
|-----------|--------------------|---------------------|--------|-------|--------|--------|-------|------------------------------------|
| | | A | B | C | D | E | F | |
| 15B045 | 1/2" | 11.250 | 5.625 | 4.000 | 27.125 | 20.469 | 4.969 | 1 1/4" |
| 15B070 | 1/2" | 15.125 | 7.562 | 5.000 | 28.125 | 20.969 | 4.969 | 1 1/4" |
| 15B096 | 1/2" | 15.125 | 7.562 | 5.000 | 28.125 | 20.969 | 4.969 | 1 1/4" |
| 15B120 | 1/2" | 19.000 | 9.500 | 6.000 | 29.125 | 21.469 | 5.469 | 1 1/4" |
| 15B145 | 1/2" | 19.000 | 9.500 | 6.000 | 29.125 | 21.469 | 5.469 | 1 1/4" |
| 15B175 | 1/2" | 22.875 | 11.438 | 7.000 | 30.125 | 21.969 | 5.969 | 1 1/4" |
| 15B195 | 1/2" | 22.875 | 11.438 | 7.000 | 30.125 | 21.969 | 5.969 | 1 1/4" |
| 15B245 | 3/4" | 26.750 | 13.375 | 8.000 | 31.125 | 22.469 | 6.969 | 1 1/4" |
| 15B295 | 3/4" | 30.625 | 15.312 | 9.000 | 32.125 | 22.969 | 8.969 | 1 1/4" |

* Propane Gas Inlet (All Units) 1/2"

INSTALLATION PROCEDURE

! WARNING

Improper installation, adjustment, alteration, service or maintenance can cause injury or property damage.

1. The installation must conform to the requirements of the authority having jurisdiction or, in the absence of such requirements, to the latest revision of the National Fuel Gas Code, ANSI Z223. (Available from the American Gas Association, 8501 E. Pleasant Valley Road, Cleveland, Ohio 44134). Reference should also be made to local gas utility regulations and other codes in effect in the area in which the installation is to be made. When installed in Canada: The latest revision of the CAN1-B149.1 and/or B149.2 Installation Codes for Gas-Burning Equipment and/or local codes.
2. Where required by the authority having jurisdiction, the installation must conform to American Society of Mechanical Engineers Safety Code for Controls and Safety Devices For Automatically Fired Boilers, ANSI/ASME No.CSD-1.
3. This boiler series is classified as a Category 1 and the vent installation shall be in accordance with Part 7 of the National Fuel Gas Code noted above when installed in the United States. In Canada refer to the CAN1-B149.1 and or B149.2 Installation Codes for Gas-Burning Equipment. Also refer to applicable provisions of the local building codes.
4. This boiler has met safe lighting and other performance criteria with the gas manifold and control assembly on the boiler per the latest revision of ANSI Z21.13/CGA 4.9.
5. The boiler shall be installed such that the gas ignition system components are protected from water (dripping, spraying, rain, etc.) during appliance operation and service, (circulator replacement, condensate trap, control replacement, etc.).
6. Locate boiler on level, solid base as near the chimney as possible and centrally located with respect to the heat distribution system as practical.
7. Allow 24 inches at the front and right side for servicing and cleaning.
8. When installed in a utility room, the door should be wide enough to allow the largest boiler part to enter, or to permit replacement of another appliance such as a water heater.

9. **FOR INSTALLATION ON NON-COMBUSTIBLE FLOORS ONLY** - For installation on combustible flooring special base must be used. (See Replacement Parts Section.) The boiler can not be installed on carpeting. Minimum clearances to combustible construction are:

| | |
|----------------------|----------|
| TOP | 18 IN. |
| FRONT | ALCOVE * |
| FLUE CONNECTOR | 6 IN. |
| REAR..... | 8 IN. |
| CONTROL SIDE..... | 9 IN. |
| OTHER SIDE..... | 3 IN. |

NOTE: Greater clearances for access should supersede fire protection clearances.

- * The definition of an Alcove is a three sided space with no wall in front of the boiler. The ANSI standard for an alcove is 18 inches from the front of an appliance to the leading edge of the side walls as shown below.

Minimum Clearances to Combustible Construction (as seen from above)

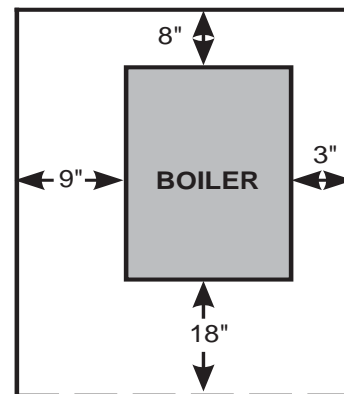

VENTILATION & COMBUSTION AIR



WARNING

Air openings to combustion area must not be obstructed. By following the instructions below, adequate combustion air can be maintained.

COMBUSTION AIR REQUIREMENTS

(Minimum Square Inches Requirement)

| Model No. | Unconfined Area* | | Confined Area** | |
|-----------|----------------------------------|----------------------------------|---------------------------------------|---|
| | Inside Combustion Air | Outside Combustion Air | Outside Combustion Air | |
| | 1 Sq. In./1000 Btu/Hr. (Fig. #3) | 1 Sq. In./5000 Btu/Hr. (Fig. #4) | Vertical Ducts 1 Sq. In./4000 BTU/Hr. | Horizontal Ducts 1 Sq. In./2000 BTU/Hr. |
| 15B045 | 100 | 10 | 13 | 25 |
| 15B070 | 100 | 15 | 19 | 38 |
| 15B096 | 100 | 20 | 25 | 50 |
| 15B120 | 125 | 25 | 32 | 63 |
| 15B145 | 150 | 30 | 38 | 75 |
| 15B175 | 175 | 35 | 44 | 88 |
| 15B195 | 200 | 40 | 50 | 100 |
| 15B245 | 250 | 50 | 63 | 125 |
| 15B295 | 300 | 60 | 75 | 150 |

* A space whose volume is not less than 50 cubic feet per 1000 BTU per hour of all appliances installed in that space (cubic feet of space = height x width x length)

** A space whose volume is less than 50 cubic feet per 1000 BTU per hour of all appliances installed in that space (cubic feet of space = height x width x length)

- Ventilation of the boiler room must be adequate to provide sufficient air to properly support combustion per the latest revision of the National Fuel Gas Code, ANSI Z223.1.

Figure #1

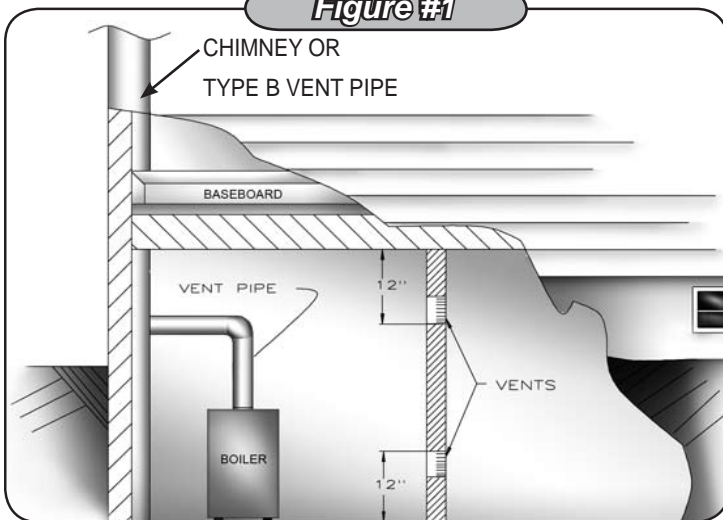

- When a boiler is located in an unconfined space in a building or conventional construction frame, masonry or metal building, infiltration normally is adequate to provide air for combustion and ventilation. However, if the equipment is located in a building of tight construction (See the National Fuel Gas Code, ANSI Z223.1 latest revision), the boiler area should be considered as a confined space.

In this case air for combustion and ventilation shall be provided according to Step 5. If there is any doubt, install air supply provisions in accordance with the latest revision of the National Fuel Gas Code.

- When a boiler is installed in an unconfined space in a building of tight construction, air for combustion and ventilation must be obtained from outdoors or from spaces freely communicating with the outdoors. A permanent opening or openings having a total free area of not less than 1 square inch per 5000 Btu per hour of total input rating of all appliances shall be provided. Ducts may be used to convey makeup air from the outdoors and shall have the same cross-sectional area of the openings to which they are connected.
- When air for combustion and ventilation is from inside buildings, the confined space shall be provided with two permanent openings, one starting 12 inches from the top and one 12 inches from the bottom of the enclosed space. Each opening shall have a minimum free area of 1 square inch per 1000 Btu per hour of the total input rating of all appliances in the enclosed space, but must not be less than 100 square inches. These openings must freely communicate directly with other spaces of sufficient volume so that the combined volume of all spaces meets the criteria for an unconfined space. (Figure #1)
- When the boiler is installed in a confined space and all air is provided from the outdoors the confined space shall be provided with one or two permanent openings according to methods A or B. When ducts are used, they shall be of the same cross sectional area as the free area of the area of the openings to which they connect. The minimum dimension of rectangular air ducts shall be not less than 3 x 3 inches or 9 square inches.
- When installing two openings, one must commence within 12 inches from the top and the other within 12 inches from the bottom of the enclosure. The openings shall communicate directly, or by ducts, with the outdoors or spaces (crawl or attic) that freely communicate with the outdoors. One of the following methods must be used to provide adequate air for ventilation and combustion.

VENTILATION AND COMBUSTION AIR

- When directly communicating with the outdoors, each opening shall have a minimum free area of 1 square inch per 4,000 Btu per hour of total input rating of all equipment in the enclosure. (Figure #2)

Figure #2

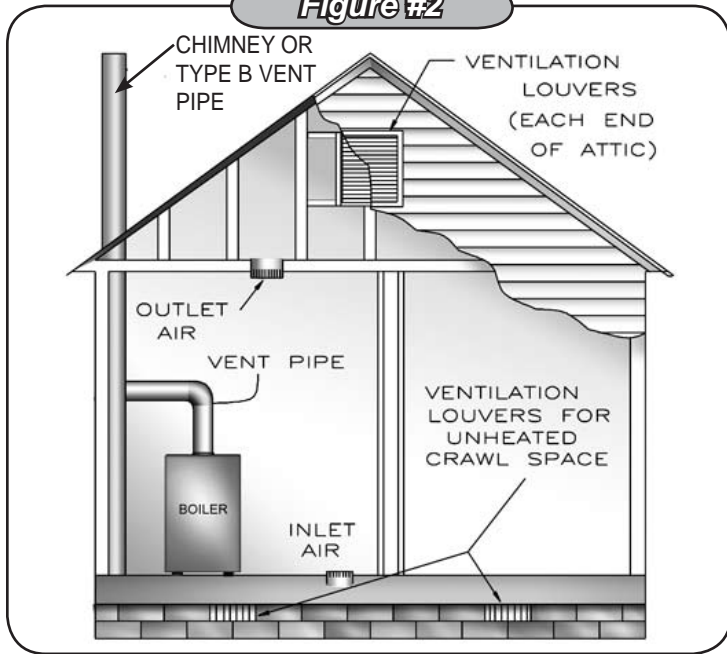

- When communicating with the outdoors by means of vertical ducts, each opening shall have a minimum free area of 1 square inch per 4,000 Btu per hour of total input rating of all appliances in the enclosed space. (Figure #3)

Figure #3

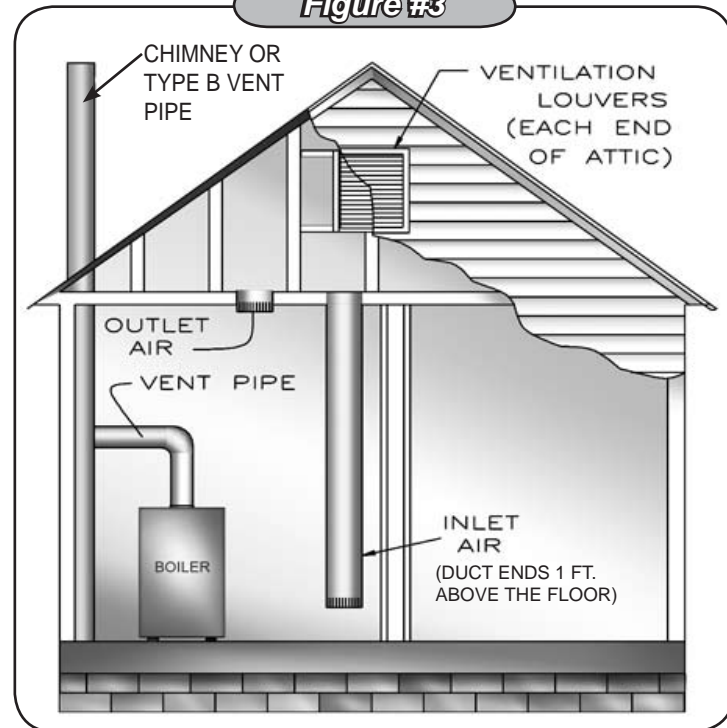

- If horizontal ducts are used, each opening and duct shall have a minimum free area 1 square inch per 2,000 Btu per hour of total input rating of all appliances in the enclosed space. (Figure #4)

Figure #4

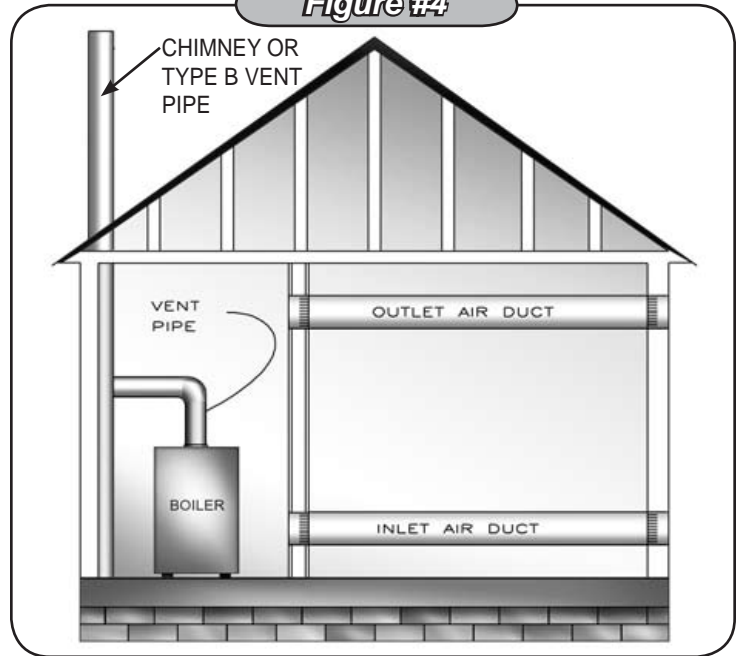

- One permanent opening, commencing within 12 inches of the top of the enclosure, shall be permitted where the equipment has clearances of at least 1 inch from the sides, 1 inch from the back, and 6 inches from the front of the boiler. The opening shall directly communicate with the outdoors or shall communicate through a vertical or horizontal duct to the outdoors or spaces (crawl or attic) that freely communicate with the outdoors. The openings must have a minimum free area of 1 square inch per 3000 Btu per hour of the total input rating of all equipment located in the enclosure. The free area must be no less than the sum of the areas of all vent connectors in the confined space.
- In calculating free area using louvers, grilles or screens for the above, consideration shall be given to their blocking effect. Screens used shall not be smaller than 1/4 inch mesh. If the free area through a design of louver or grill is known, it should be used in calculating the size opening required to provide the free area specified. If the design and free area is not known, it may be assumed that wood louvers will have 20-25% free area and metal louvers and grilles will have 60-75% free area. Louvers and grilles should be fixed in the open position or interlocked with the boiler so they are opened automatically during the boiler operation.

CONNECTING SUPPLY & RETURN PIPING

IMPORTANT: Circulators in the following illustrations are mounted on the system supply side, but mounting on the system return side is also acceptable practice.

Figure #5

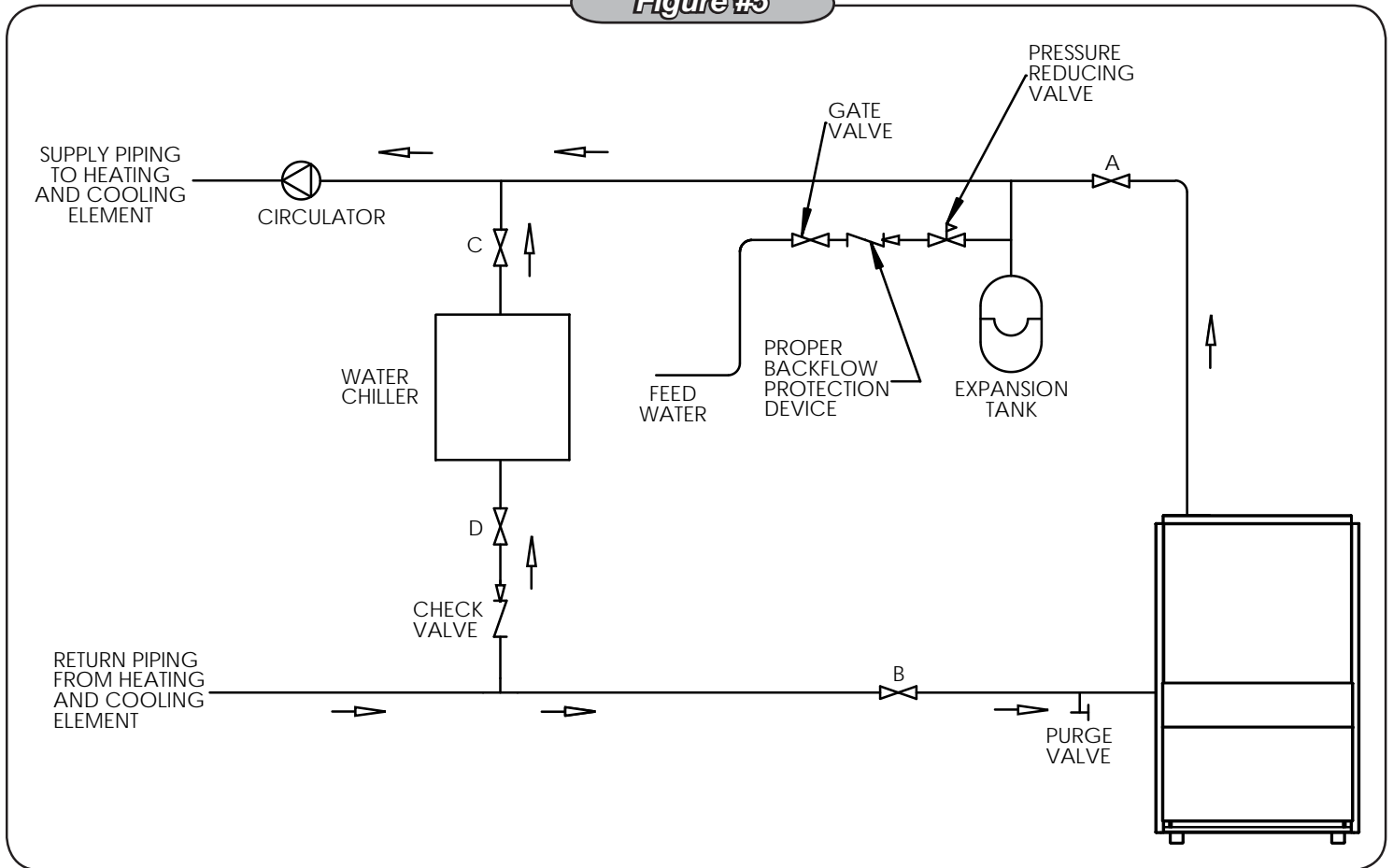

1. Connect supply and return piping as suggested in Figure #5 when the boiler is used in connection with refrigerated systems.

- A. The chilled medium MUST BE PIPED IN PARALLEL with the boiler.
- B. Use appropriate valves to prevent the chilled medium from entering the heating boiler.
 - During heating cycle open valves A and B, close valves C and D.
 - During cooling cycle, open valves C and D, close valves A and B.
- C. Maintain a minimum clearance of one inch to hot water pipes.

2. When the boiler is connected to heating coils located in air

handling units where they may be exposed to refrigerated air circulation, the boiler piping system MUST BE supplied with flow control valves or other automatic means to prevent gravity circulation of the boiler water during the cooling cycle.

3. Hot water boilers installed above radiation level must be provided with a low water cut-off device.
4. When a boiler is connected to a heating system that utilizes multiple zoned circulators, each circulator must be supplied with a flow control valve to prevent gravity circulation.
5. Hot water boilers and system must be filled with water and maintained to a minimum pressure of 12 pounds per square inch.

CONNECTING SUPPLY AND RETURN PIPING

Figure #6

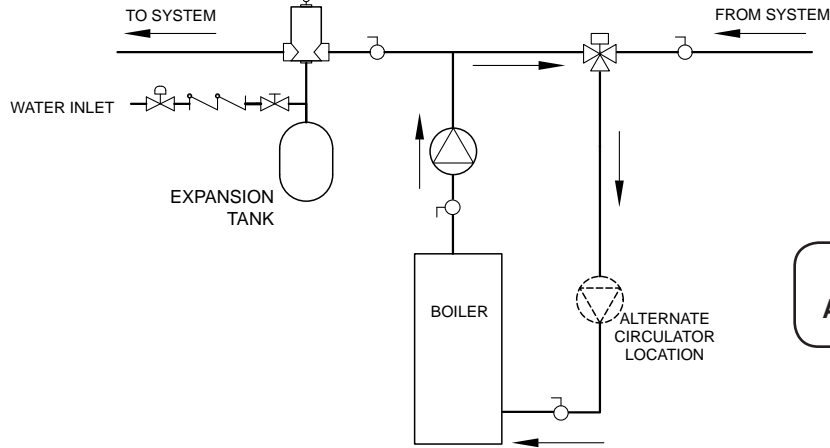

**BYPASS PIPING -
AUTOMATIC MIXING VALVE**

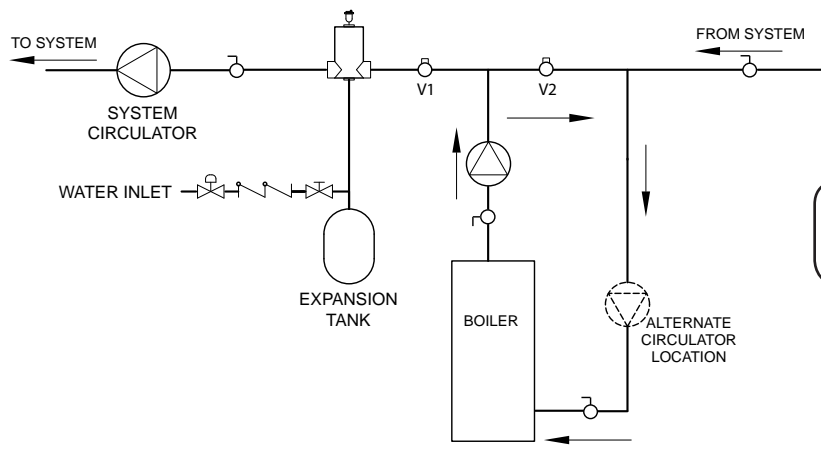
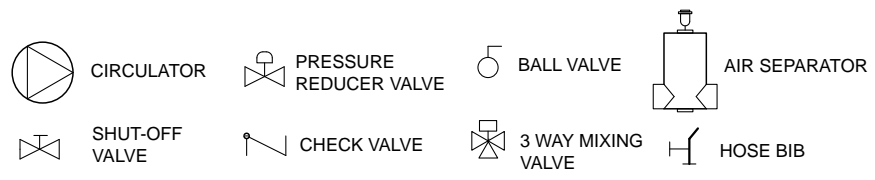

**BYPASS PIPING -
FIXED LOW TEMP ONLY**

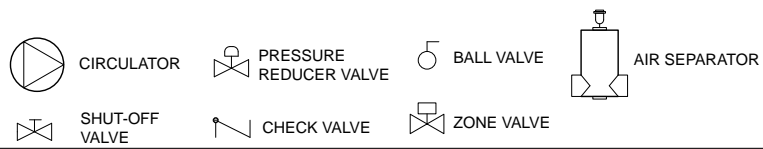

6. Bypass piping is an option which gives the ability to adjust the supply boiler water temperature to fit the system or the condition of the installation. This method of piping, however, is not typically required for baseboard heating systems. Typical installations where bypass piping is used are as follows:

- A. This method is used to protect boilers from condensation forming due to low temperature return water. Generally noticed in large converted gravity systems or other large water volume systems. **(Figure #6)**
- B. These methods are used to protect systems using radiant panels and the material they are encased in from

high temperature supply water from the boiler and protect the boiler from condensation.

NOTE#1: When using bypass piping, adjust valves V1 & V2 until desired system temperature is obtained.

NOTE#2: Bypass loop must be same size piping as the supply and return piping.

7. Installation using circulators and zone valves are shown in **Figures #7-#10**. For further piping information refer to the I=B=R Installation and Piping Guide.

CONNECTING SUPPLY AND RETURN PIPING

Figure #7

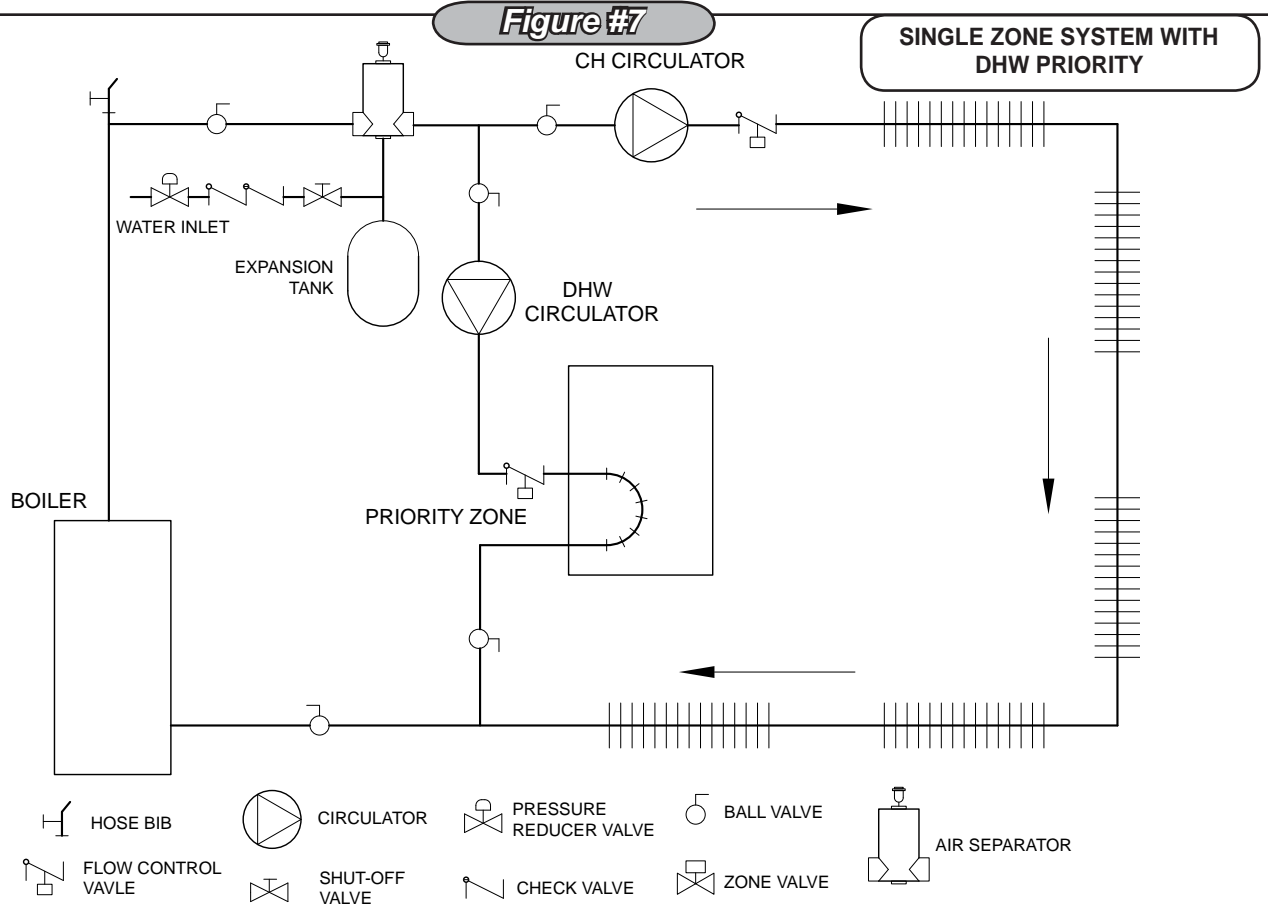
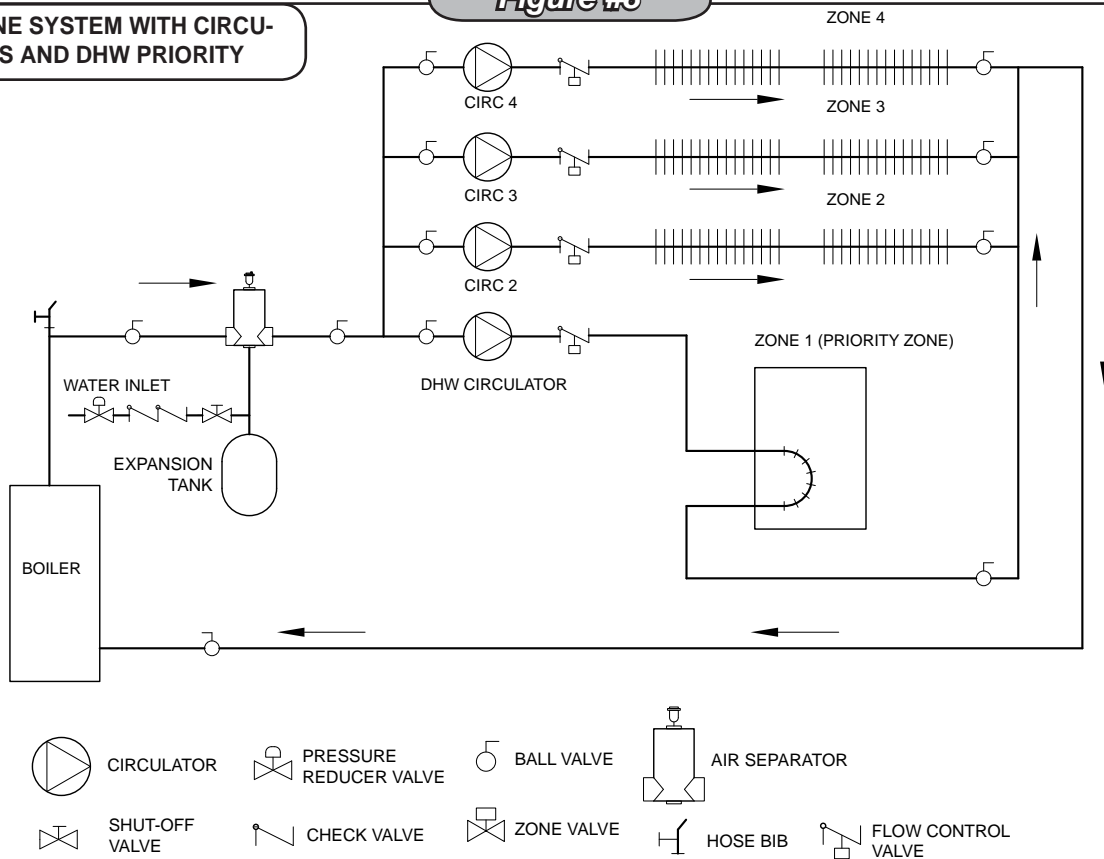

Figure #8

MULTIZONE SYSTEM WITH CIRCULATORS AND DHW PRIORITY



CONNECTING SUPPLY AND RETURN PIPING

Figure #9

MULTIZONE SYSTEM WITH ZONE VALVES AND DHW PRIORITY (WITH CIRCULATOR)

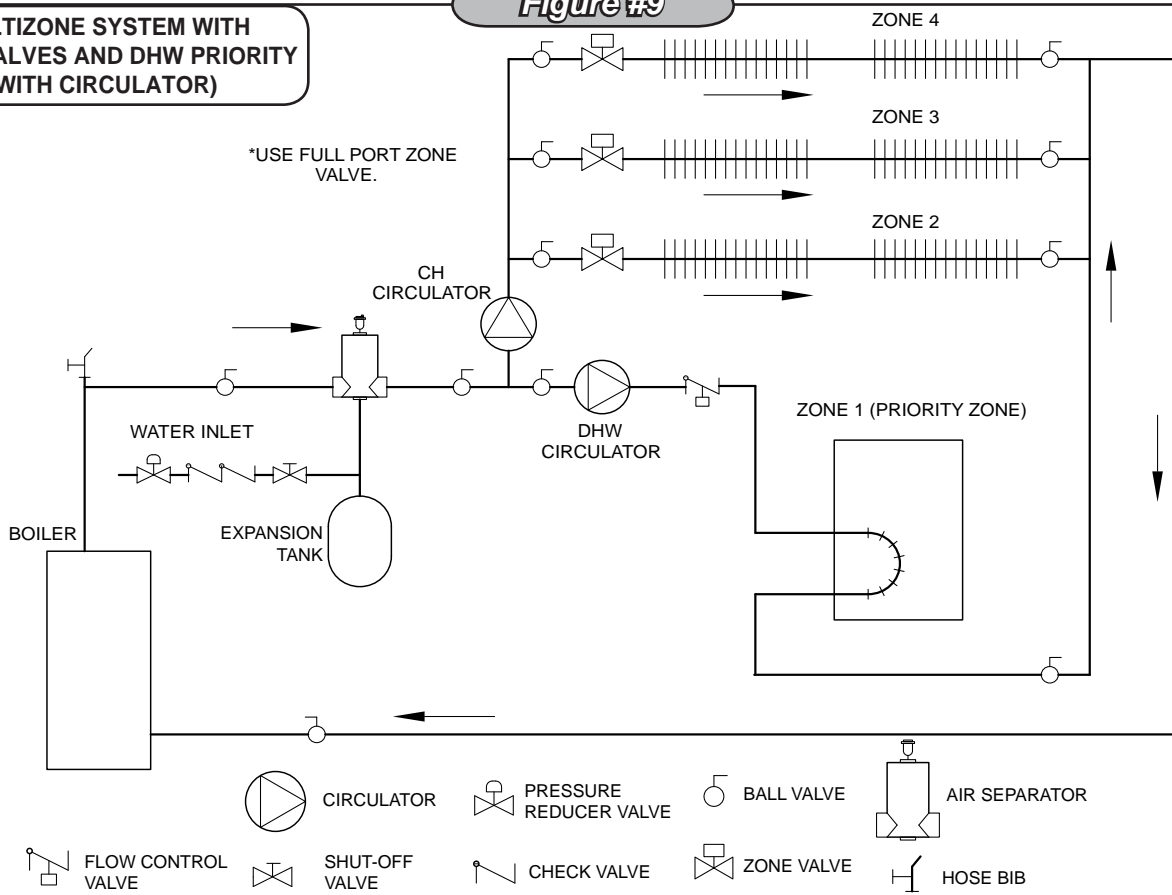
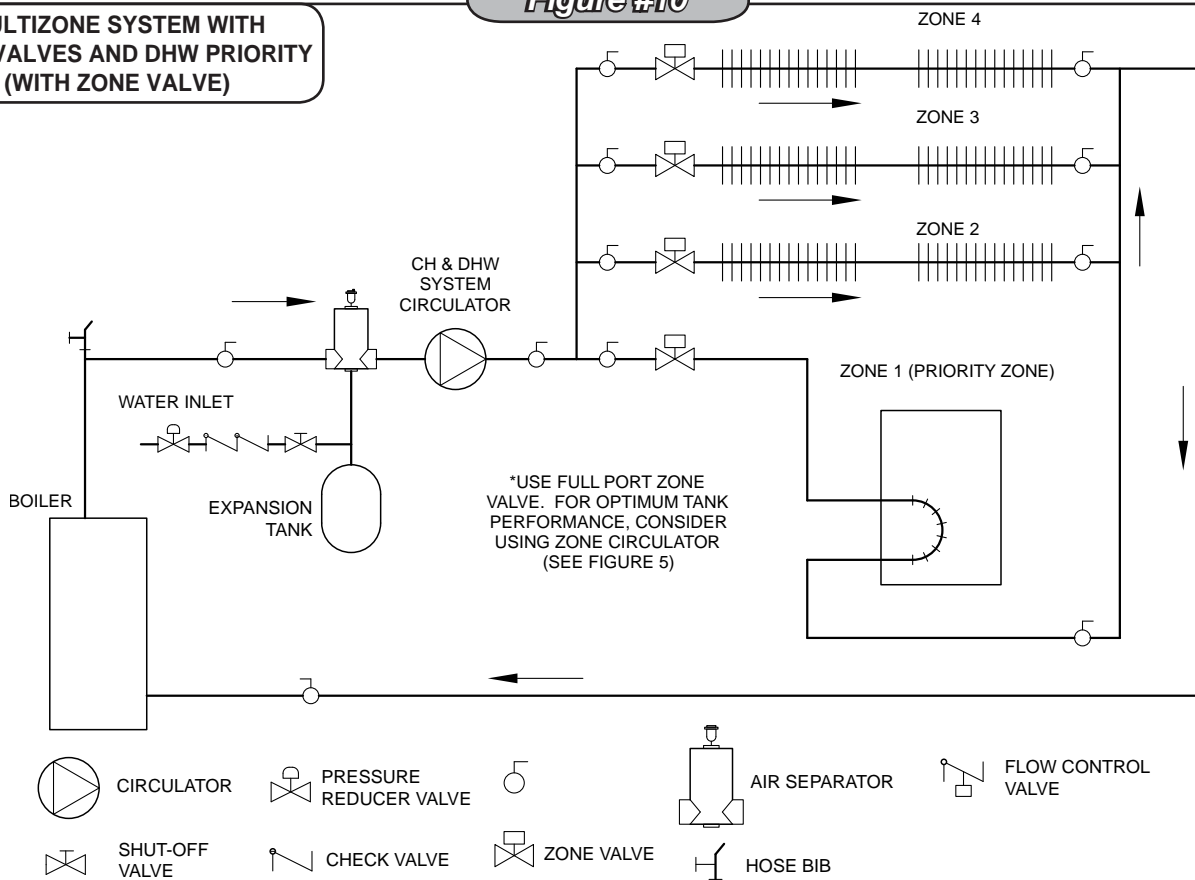

Figure #10

MULTIZONE SYSTEM WITH ZONE VALVES AND DHW PRIORITY (WITH ZONE VALVE)



VENT INSTALLATION

WARNING

All installations of boilers and venting should be done only by a qualified expert and in accordance with the appropriate manual. Installing or venting a boiler or any other gas appliance with improper methods or materials may result in serious injury or death due to fire or to asphyxiation from poisonous gases such as carbon monoxide which is odorless and invisible.

WARNING

This boiler shall not be connected to any portion of a mechanical draft system operating under positive pressure.

1. The vent pipe must slope upward from the boiler not less than $\frac{1}{4}$ inch for every 1 foot to the vent terminal.
2. Horizontal portions of the venting system shall be supported rigidly every 5 feet and at the elbows. No portion of the vent pipe should have any dips or sags.
3. This boiler series is classified as a Category 1 and the vent installation shall be in accordance with latest revision of the National Fuel Gas Code noted above or applicable provisions of the local building codes.
4. Inspect chimney to make certain it is constructed according to NFPA 211. The vent or vent connector shall be Type B or metal pipe having resistance to heat and corrosion not less than that of galvanized sheet steel or aluminum not less than 0.016 inch thick (No. 28 Ga).
5. Connect flue pipe from draft hood to chimney. Bolt or screw joints together to avoid sags. Flue pipe should not extend beyond inside wall of chimney. Do not install manual damper in flue pipe or reduce size of flue outlet except as provided by the latest revision of ANSIZ223.1. Protect combustible ceiling and walls near flue pipe with fireproof insulation. Where two or more appliances vent into a common flue, the area of the common flue must be at least equal to the area of the largest flue plus 50 percent of the area of each additional flue.

VENT SYSTEM MODIFICATION

When an existing boiler is removed from a common venting system, the system is likely to be too large for the proper venting of the appliances still connected to it. If this situation occurs, the following test procedure must be followed:

REMOVAL OF BOILER FROM VENTING SYSTEM

At the time of removal of an existing boiler, the following steps shall be followed with each appliance remaining connected to the common venting system placed in operation, while the other appliances remaining connected to the common venting system are not in operation.

1. Seal an unused opening in the common venting system.
2. Visually inspect the venting system for proper size and horizontal pitch and determine there is no blockage or restriction, leakage, corrosion and other deficiencies which could cause an unsafe condition.
3. Insofar as is practical, close all building doors and windows and all doors between the space in which the appliances remaining connected to the common venting system are located and other spaces of the building. Turn on clothes dryers and any other appliance not connected to the common venting system. Turn on any exhaust fans, such as range hoods and bathroom exhausts, so they operate at maximum speed. Do not operate a summer exhaust fan. Close fireplace dampers.
4. Place in operation the appliance being inspected. Follow the lighting instructions. Adjust thermostat so appliance will operate continuously.
5. Test for spillage at the draft hood relief opening after 5 minutes of main burner operation. Use the flame of a match or candle, or smoke from a cigarette, cigar or pipe.
6. After it has been determined that each appliance remaining connected to a common venting system properly vents when tested as outlined above, return doors, windows, exhaust fans, fireplace dampers and any other gas burning appliances to their previous condition of use.
7. Any improper operation of the common venting system

VENT SYSTEM MODIFICATION

should be corrected so the installation conforms with the latest revision of the National Fuel Gas Code, ANSI Z223.1. When resizing any portion of the common venting system, the common venting system should be resized to approach the minimum size as determined using the appropriate tables in the latest revision of the National Fuel Gas Code, ANSI Z223.

VENT DAMPER INSTALLATION & INSTRUCTIONS

DAMPER INSTALLATION

NOTE: Refer to *Figure #11* for steps 1-6.

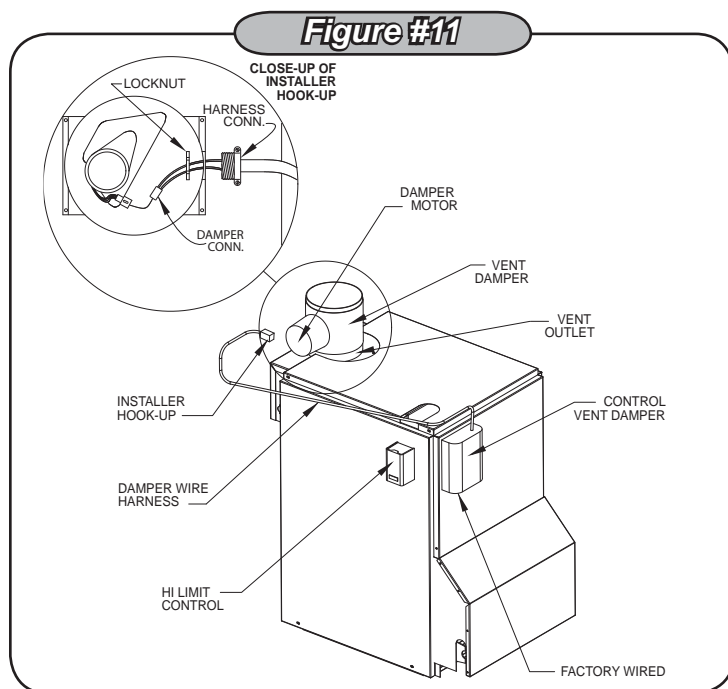

1. Place Vent Damper on or as close to vent outlet of boiler as possible. (Figure #12)
2. Remove Vent Damper Motor cover.
3. Feed damper wire harness connector through bracket hole on Damper Motor frame.
4. Tighten locknut onto Damper wire harness connector.
5. Plug Damper connector into socket on Damper Motor frame.
6. Replace Damper Motor cover and wire Damper in accordance with Figure #11.

DAMPER INSTRUCTIONS

1. Ensure that only the boiler is serviced by the Vent Damper. (Figure #12)

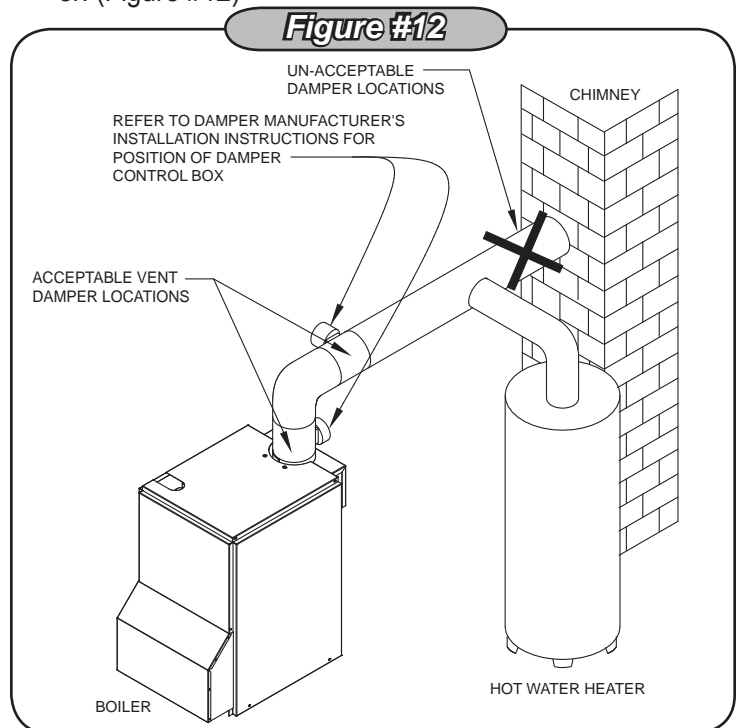

2. Clearance of not less than 6 inches between Vent Damper and combustible material must be maintained. Additional clearance should be allowed for service of Vent Damper.
3. Vent Damper must be in the open position when appliance main burners are operating.
4. The Vent Damper position indicator must be in a visible location following installation.
5. The thermostat's heat anticipator must be adjusted to match the total current draw of all controls associated with the boiler during a heating cycle.

CONNECTING GAS SERVICE

1. Connect gas service from meter to control assembly in accordance with ANSI Z223.1 and local codes or utility. A ground joint union should be installed for easy removal of gas control for servicing. A drip leg or trap must be installed at the bottom of a vertical section of piping at the inlet to the boiler. A pipe compound resistant to the action of liquified petroleum gases must be used on all threaded pipe connections. Check with the local utility for location of manual shutoff valve if required. (Figure #13)

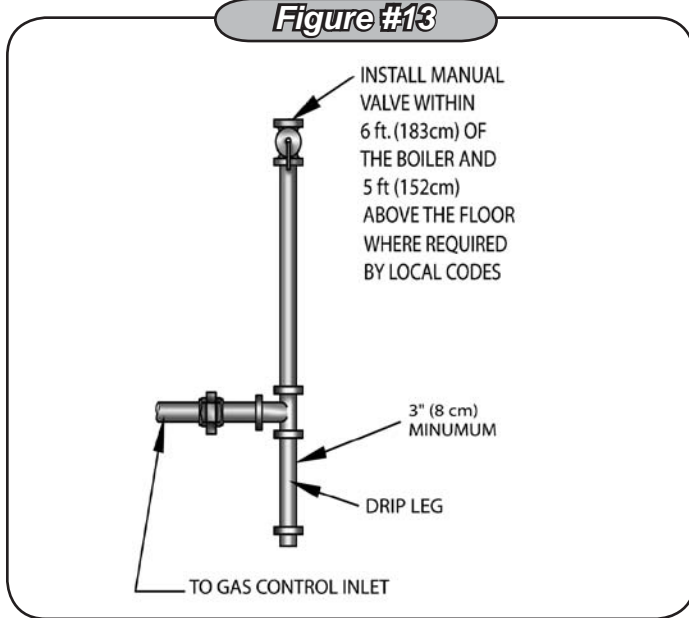

2. The gas line should be of adequate size to prevent undue pressure drop and never smaller than the pipe size of the main gas control valve. (See Chart)

MAXIMUM CAPACITY OF PIPE IN CUBIC FEET OF GAS/HOUR
(Gas Pressure = 0.5 psig or less, Pressure Drop = 5 in. w/c)

| Length of Pipe (Feet) | Nominal Iron Pipe Size | | | |
|-----------------------|------------------------|------|-----|--------|
| | 1/2" | 3/4" | 1" | 1 1/4" |
| 10 | 175 | 360 | 680 | 1400 |
| 20 | 120 | 250 | 465 | 950 |
| 30 | 97 | 200 | 375 | 770 |
| 40 | 82 | 170 | 320 | 660 |
| 60 | 66 | 138 | 260 | 530 |
| 80 | 57 | 118 | 220 | 460 |
| 100 | 50 | 103 | 195 | 400 |

For additional information refer to the National Fuel Gas Code Handbook.

3. To check for leaks in gas piping, use a soap and water solution or other approved method.

! WARNING

Do not use an open flame!!

4. Disconnect boiler from gas supply piping system during any pressure testing of the gas piping. After reconnecting, leak test gas connection and boiler piping before placing boiler back into operation.

| | Natural Gas | Propane |
|----------------------|-------------|------------|
| Min. Supply Pressure | 5" w.c. | 11" w.c. |
| Max. Supply Pressure | 14" w.c. | 14" w.c. |
| Manifold Pressure | 3.5" w.c. | 10.5" w.c. |

ELECTRICAL SECTION

ELECTRICAL WIRING

See wiring diagrams on the following four pages for details.

Electrical wiring must conform with the National Electrical Code, ANSI/NFPA No 70 latest edition when installed in the United States, the CSA C22.1 Canadian Electrical Code, Part 1, when installed in Canada, and/or the local authority having jurisdiction.

! WARNING

When an external electrical source is utilized, the boiler, when installed, must be electrically grounded in accordance with these requirements.

IMPORTANT: Install a fused disconnect switch between boiler and electrical panel at a convenient location.

THERMOSTAT INSTALLATION

1. Thermostat should be installed on an inside wall about four feet above the floor.
2. NEVER install a thermostat on an outside wall.
3. Do not install a thermostat where it will be affected by drafts, hot or cold pipes, sunlight, lighting fixtures, televisions, a fireplace, or a chimney.
4. Check thermostat operation by raising and lowering thermostat setting as required to start and stop the burners.
5. Instructions for the final adjustment of the thermostat are packaged with the thermostat (adjusting heating anticipator, calibration, etc.)

WIRING DIAGRAM - 24V STANDING PILOT

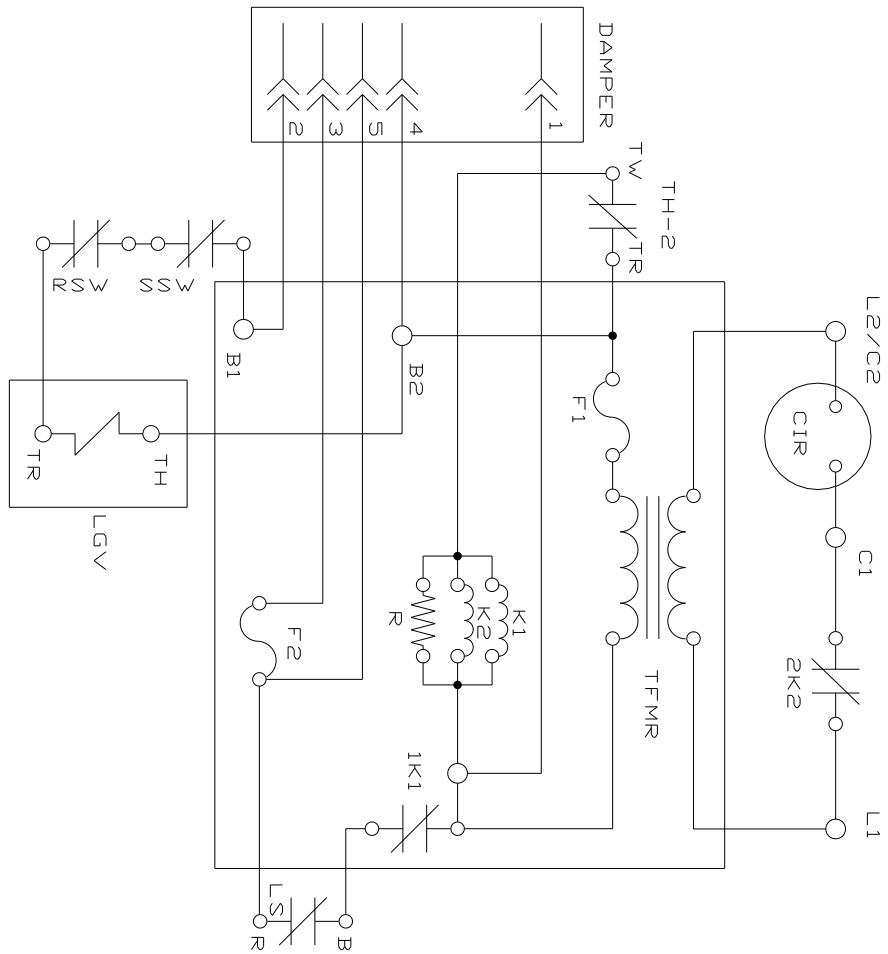
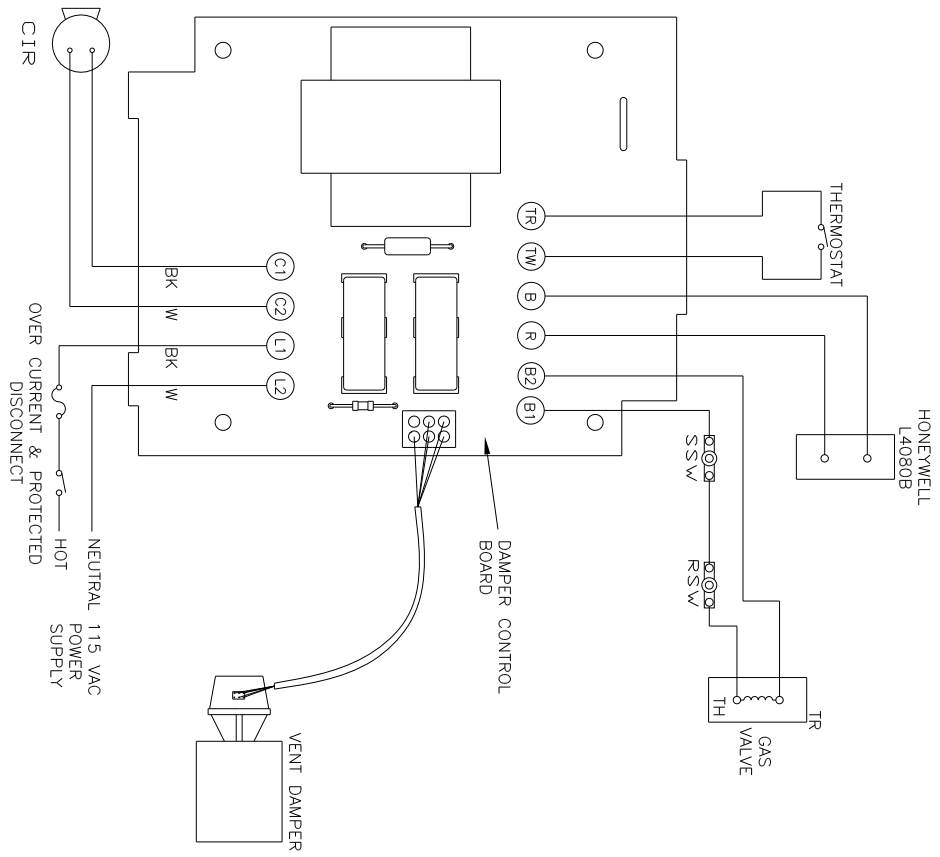

WIRING DIAGRAM - 24V INTERMITTENT IGNITION

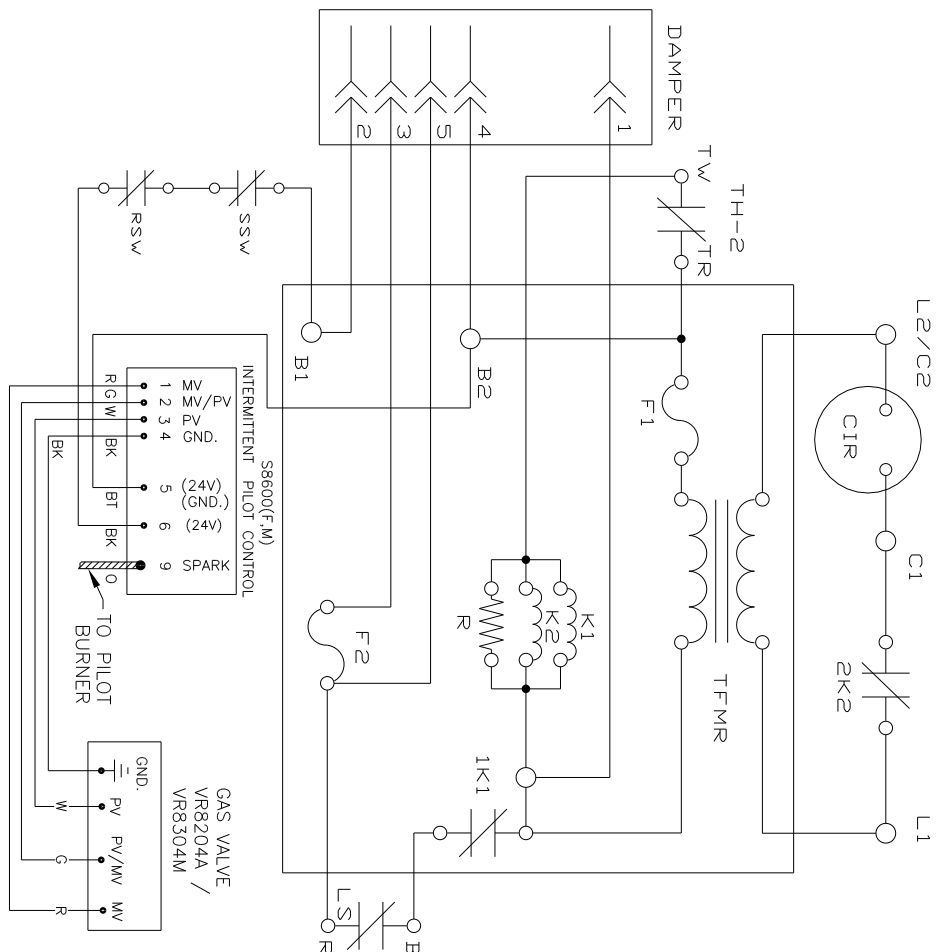
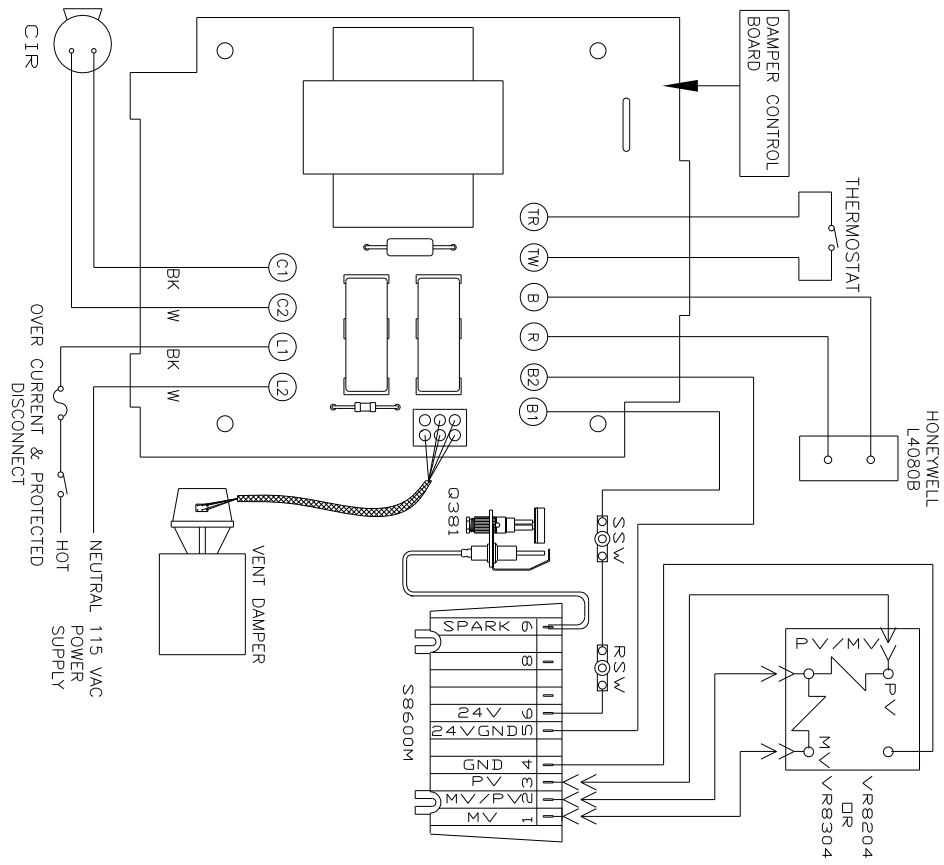

WIRING DIAGRAM - 24V STANDING PILOT WITH LWCO

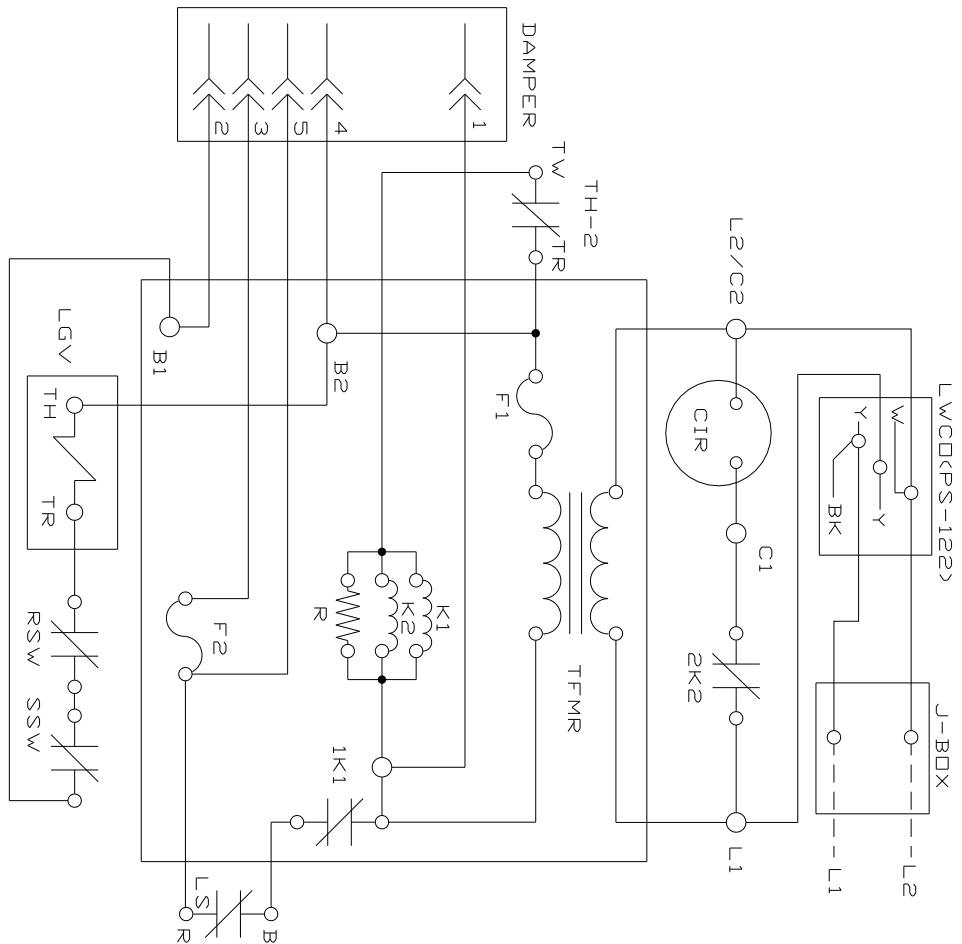
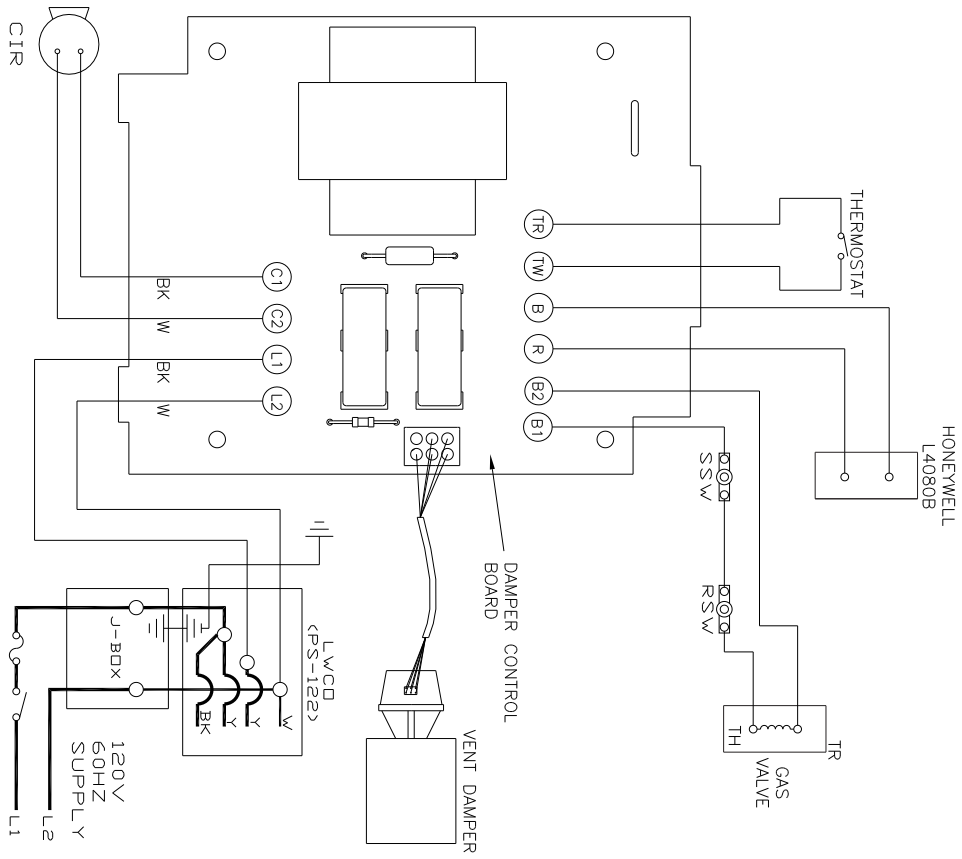

WIRING DIAGRAM - 24V INTERM IGNITION WITH LWCO

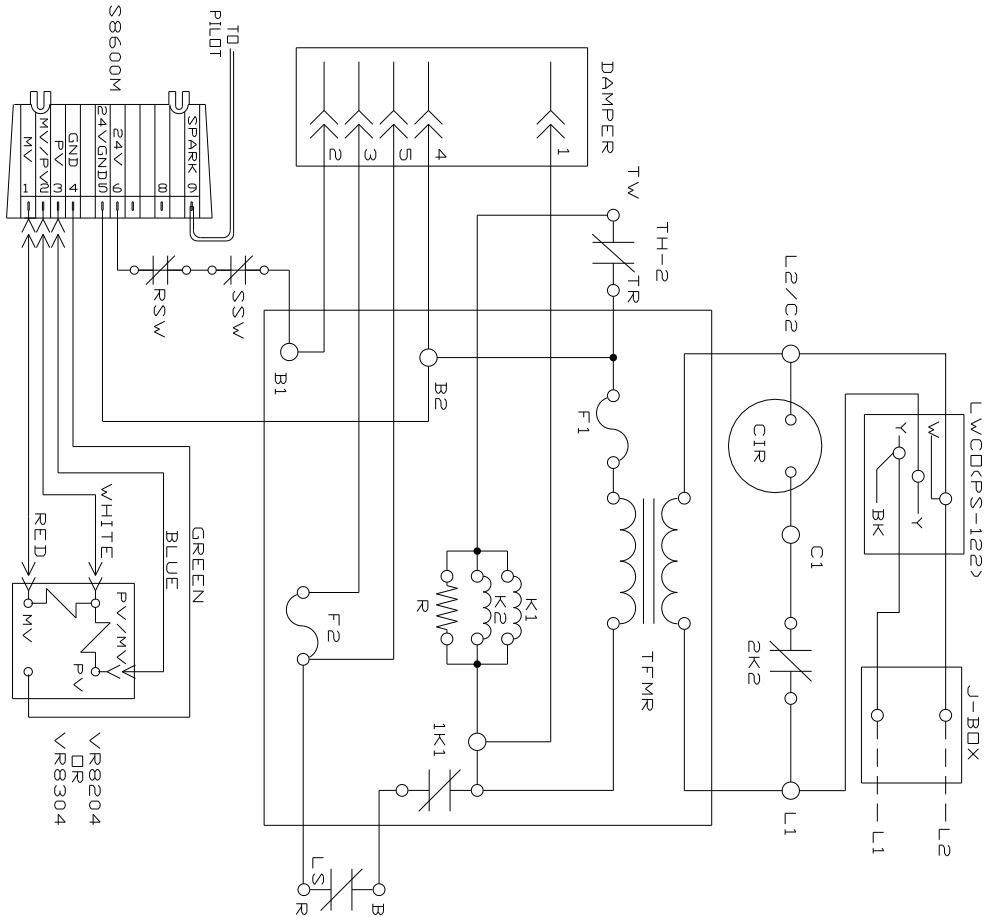
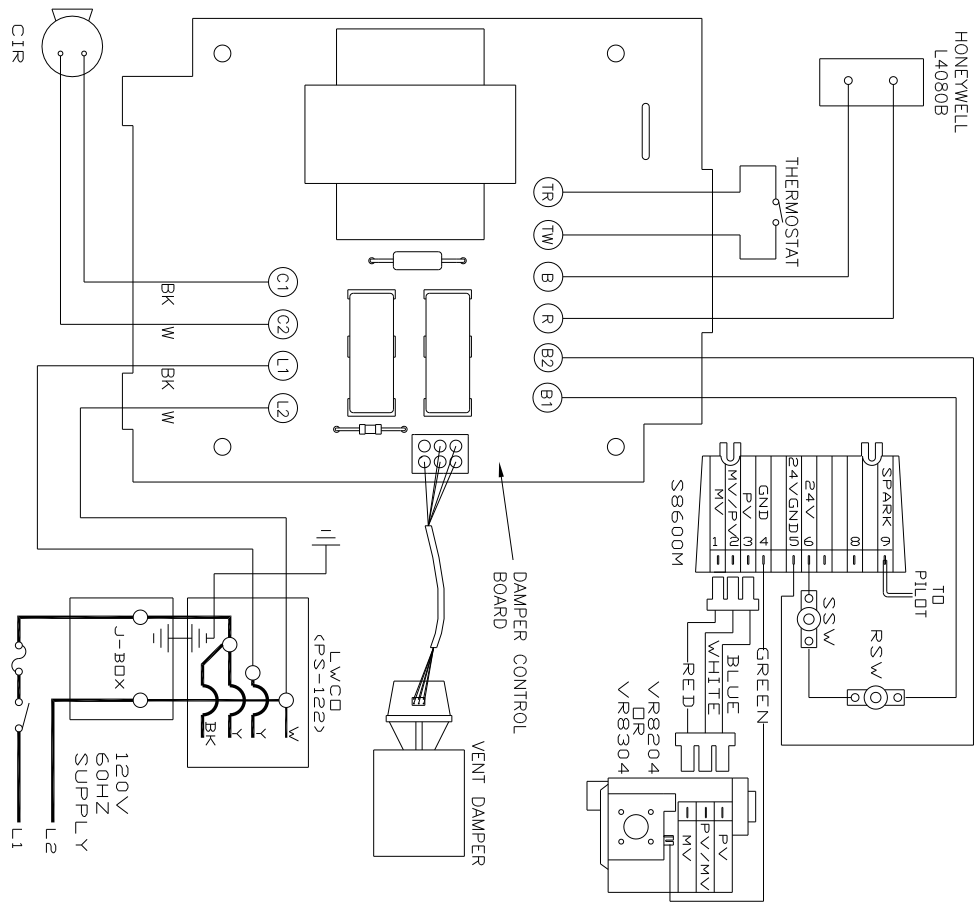

LIGHTING INSTRUCTIONS

⚠ WARNING

IF YOU DO NOT FOLLOW THESE INSTRUCTIONS EXACTLY, A FIRE OR EXPLOSION MAY RESULT, CAUSING PROPERTY DAMAGE, PERSONAL INJURY OR LOSS OF LIFE.

Before any procedures are attempted on this appliance, it is necessary to determine if the ignition system is electric or standing pilot. If you are uncertain, contact the manufacturer before proceeding.

⚠ WARNING

Before lighting any type of pilot burner (standing or intermittent), make certain the hot water boiler and system are full of water to minimum pressure of 12 lbs. per square inch in the system, and also make certain that the system is vented of air. Set the operating control of thermostat to a “below” normal setting. Refer to the following appropriate lighting instruction.

LIGHTING PROCEDURE FOR BOILER WITH INTERMITTENT PILOT SYSTEM

For Your Safety, Read Before Operating!!

1. A. This appliance is equipped with an ignition device which automatically lights the pilot. Do not try to light the appliance by hand.
2. B. Before operating, smell all around the appliance area for gas. Be sure to smell next to the floor because some gas is heavier than air and will settle on the floor.

⚠ CAUTION

WHAT TO DO IF YOU SMELL GAS

- Do not try to light any appliance.
- Do not touch any electrical switches; do not use any phones in your building.
- Immediately call your gas supplier from a neighbor’s phone. Follow the gas supplier’s instructions.
- If you cannot reach your gas supplier, call the fire department.

C. Use only your hand to push in or turn the gas control knob. Never use tools. If the knob will not push in or turn by hand, don’t try to repair it. Call a qualified service technician. Force or attempted repair may result in a fire or explosion.

D. Do not use this appliance if any part has been under water. Immediately call a qualified service technician to inspect the appliance and to replace any part of the control system and any gas control which has been under water.

OPERATING INSTRUCTIONS FOR INTERMITTENT PILOT SYSTEM

1. STOP! Read the safety information in the User’s Information Manual.
2. Set the thermostat to lowest setting.
3. Turn off all electric power to the appliance.
4. This appliance is equipped with an ignition device which automatically lights the pilot. Do not try to light the pilot by hand. (Figure #14)

Figure #14

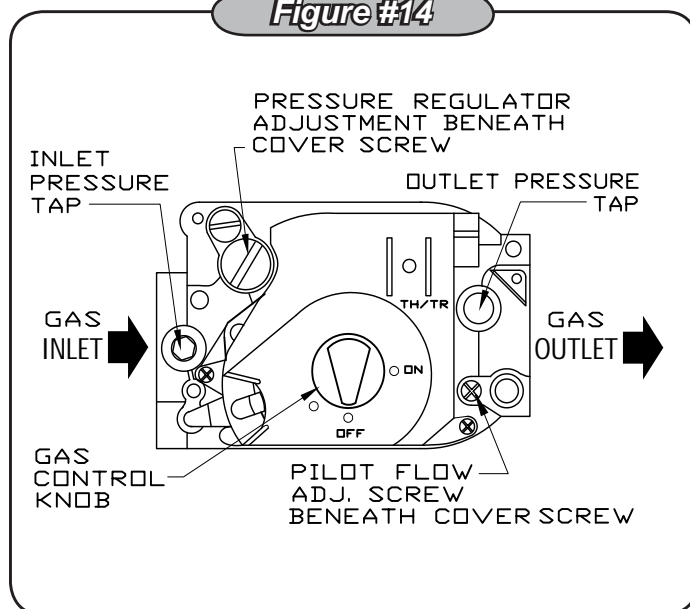

5. Turn gas control knob clockwise to “OFF.”
6. Wait (5) minutes to clear out any gas. If you then smell gas, STOP! Follow “What To Do If You Smell Gas” in the safety information above. If you don’t smell gas, go on to the next step.
7. Turn gas control knob counterclockwise to “ON.”
8. Turn on all electric power to the appliance.
9. Set thermostat to desired setting.
10. If the appliance will not operate, follow the instructions “To Turn Off Gas To Appliance” and call a qualified service technician or your gas supplier.

LIGHTING INSTRUCTIONS

LIGHTING PROCEDURE FOR BOILER WITH CONTINUOUS PILOT

For Your Safety, Read Before Lighting!!



1. Read the warning at the beginning of "**Lighting Instructions.**"
2. This appliance has a pilot which must be lighted by hand. When lighting the pilot, follow these instructions exactly.
3. Before lighting, smell all around the appliance area for gas. Be sure to smell next to the floor because some gas is heavier than air and will settle on the floor. See section "**What To Do If You Smell Gas.**"
4. Use only your hand to push in or turn gas control knob or reset button. Never use tools. If the knob or reset button will not push in or turn by hand, don't try to repair it, call a qualified service technician. Force or attempted repair may result in a fire or explosion.
5. Do not use this appliance if any part has been under water. Immediately call a qualified service technician to inspect the appliance and to replace any part of the control system and any gas control which has been under water.

LIGHTING INSTRUCTIONS FOR CONTINUOUS PILOT

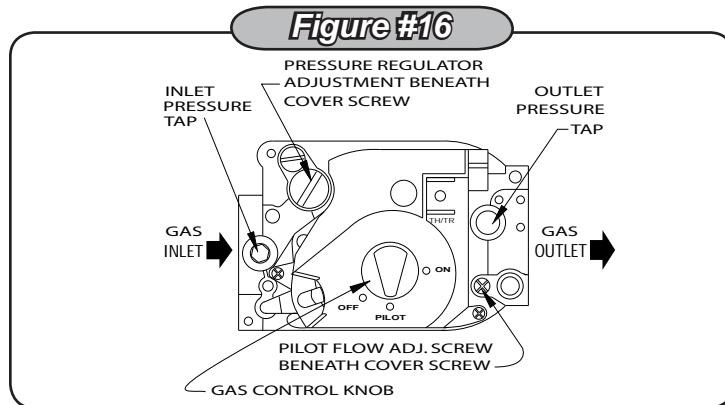
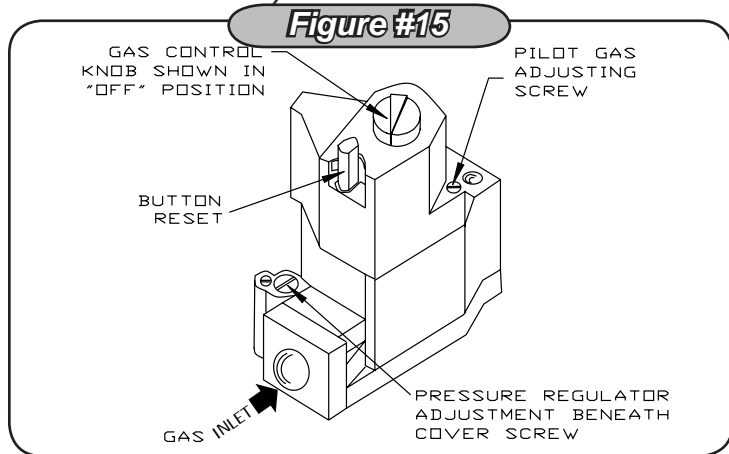
1. **STOP!** Read the safety information at the beginning of these instructions.
2. Set the thermostat to the lowest setting.
3. Turn off all electric power to the appliance.
4. Remove access panel and burner door.
5. Turn gas control knob clockwise  to "OFF." (**Figures #15 and #16**)



NOTE: Some gas control knobs cannot be turned from "PILOT" to "OFF" unless knob is pushed in slightly. **DO NOT FORCE.**

6. Wait (5) minutes to clear out any gas. If you then smell gas, STOP! Follow "**What To Do If You Smell Gas.**" If you don't smell gas, go to the next step.
7. Find pilot. Follow metal tube from gas control. Depending on the model of the boiler, pilot is either mounted on the base or on one of the burner tubes.
8. Turn gas control knob counterclockwise  to "PILOT."
9. Push in gas control knob or reset button if so equipped, all the way in and hold. Immediately light the pilot with a match. Continue to hold the gas control knob or reset button in for about 1 minute after the pilot is lit. Release knob or button, and it will pop up back up. Pilot should remain lit. If it goes out, repeat steps 5 through 9.
 - If knob or button does not pop up when released, stop and immediately call a qualified service technician or your gas supplier.
 - If the pilot will not stay lit after several tries, turn the gas control knob clockwise  to "OFF." Call a qualified service technician or your gas supplier.
10. Replace burner door.
11. Turn gas control knob counterclockwise  to "ON."
12. Replace access panel.
13. Turn on all electric power to the appliance.
14. Set thermostat to desired setting.

TO TURN OFF GAS TO THE APPLIANCE

1. Set the thermostat to lowest setting.
2. Turn off all electric power to the appliance if service is to be performed.
3. Push in gas control knob slightly and turn clockwise  to "OFF." **DO NOT FORCE.**
4. Call a qualified service technician.

NORMAL SEQUENCE OF OPERATION

On a call for heat, the thermostat will actuate, completing the circuit to the control. The completed circuit to the control will first activate the circulator and damper which will close an end switch inside the damper. This action will complete the circuit to the ignition system and ignition will take place.

In the event the boiler water temperature exceeds the high limit setting on the boiler mounted high limit control, power will be interrupted between the control system and the ignition system. The power will remain off until the boiler water temperature drops below the high limit setting. The circulator will continue to operate under this condition until the thermostat is satisfied.

In the event the flow of combustion products through the boiler venting system becomes blocked, the blocked vent safety switch will shut the main burner gas off. Similarly, if the boiler flueway becomes blocked, a flame rollout safety switch will shut the main burner gas off. **(Figure #17)** If either of these conditions occur, **DO NOT ATTEMPT TO PLACE THE BOILER BACK INTO OPERATION. CONTACT A CERTIFIED SERVICE AGENCY.**

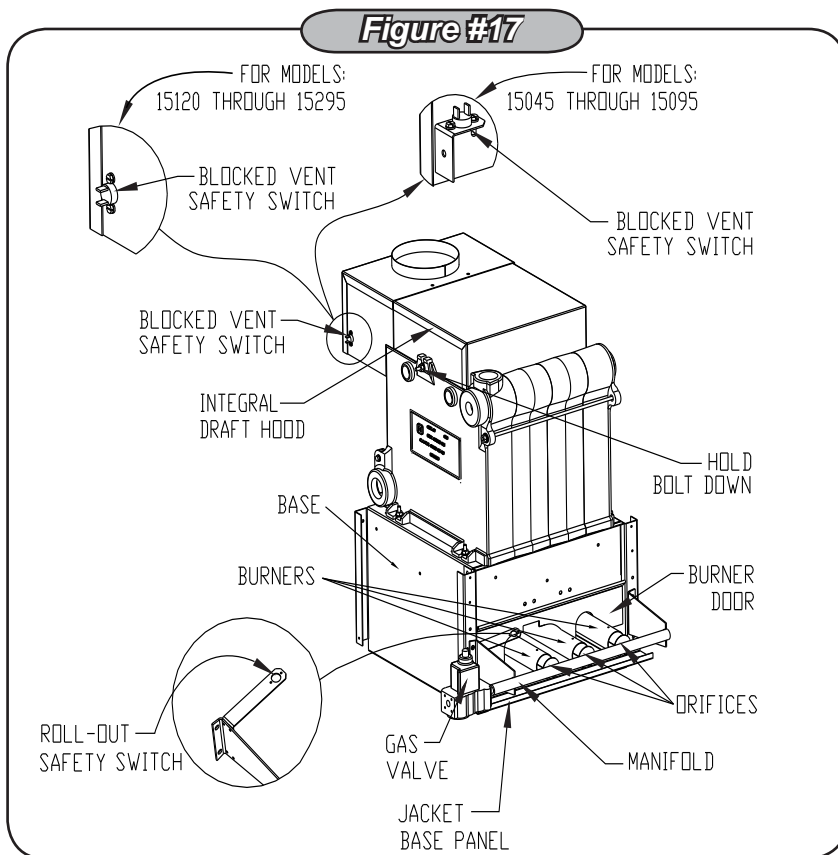

GENERAL INSTRUCTIONS

Before seasonal start-up, have a certified service agency check the boiler for soot and scale in the flues, clean the burners and check the gas input rate to maintain high operating efficiency.

CAUTION

Label all wires prior to disconnection when servicing controls. Wiring errors can cause improper and dangerous operation.

Verify proper operation after service.

The service agency or owner should make certain the system is filled with water to minimum pressure and open air vents, if used, to expel any air that may have accumulated in the system. Check the entire piping system and, if any leaks appear, have them repaired.

Circulators need to be checked and maintained. Refer to the circulator manufacturer's instructions.

The venting system should be inspected at the start of each heating season. Check the vent pipe from the boiler to the chimney for signs of deterioration by rust or sagging joints. Repair if necessary. Remove the vent pipe at the base of the chimney or flue and using a mirror, check vent for obstruction and make certain the vent is in good working order.

The boiler flue gas passageways may be inspected by a light and mirror. Remove the burner door. (Figure #20) Place a trouble lamp in the flue collector through the draft relief opening. With the mirror positioned above the burners, the flue gas passageways can be checked for soot or scale.

The following procedure should be followed to clean the flue gas passageways:

1. Remove the burners from the combustion chamber by raising the burners up from the manifold orifices and pulling toward the front of the boiler. **(Figure #20)**
2. Disconnect the vent pipe from the draft hood.
3. Remove the top jacket panel.
4. Remove the combination flue collector and draft hood from the boiler castings by loosening the nuts on the hold down bolts located on each side of the collector. **(Figure #17)**
5. Place a sheet of heavy paper or similar material over the

GENERAL INSTRUCTIONS

bottom of the base and brush down the flue passage-ways. The soot and scale will collect on the paper and is easily removed with the paper.

6. With the paper still in place in the base, clean the top of the boiler castings of the boiler putty or silicone used to seal between the castings and flue collector. Make certain that chips are not lodged in the flue passageways.

When the cleaning process is complete, restore the boiler components to their original position. Use IS-808 GE silicone (available from a distributor) to seal around the flue collector and boiler castings.

A visual check of the main burner and pilot flames should be made at the start of the heating season and again in mid-season. The main burner flame should have a well defined inner blue mantel with a lighter blue outer mantel. Check the burner throats and burner orifices for lint or dust obstruction. (Figures #19 and #20)

Figure #19

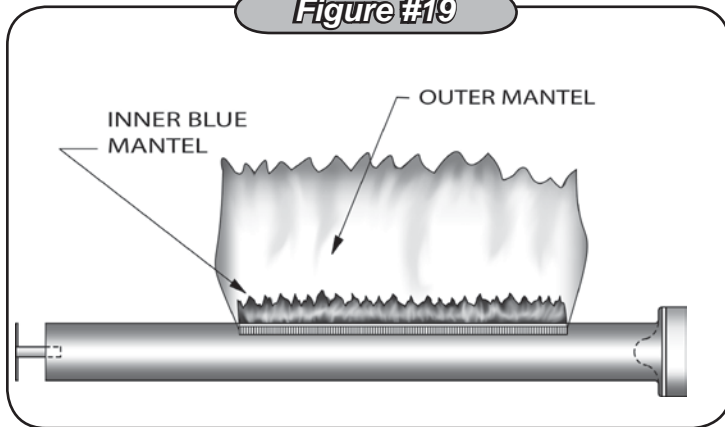
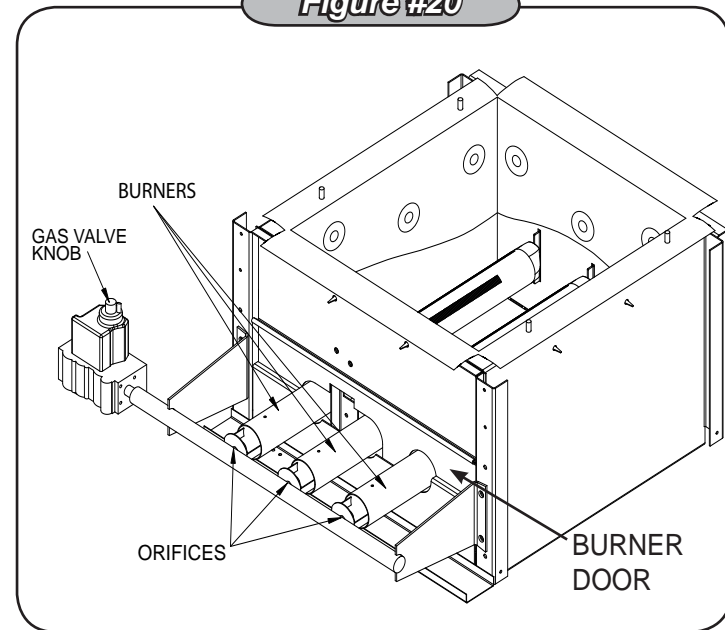
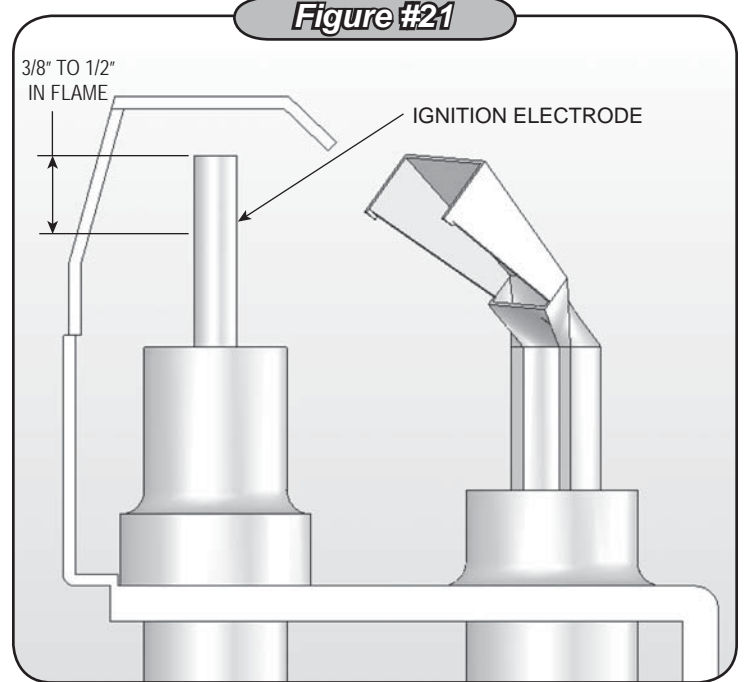



Figure #20



The pilot flame should envelop $\frac{3}{8}$ to $\frac{1}{2}$ inch of the tip of the pilot thermocouple, ignition/sensing electrode or mercury sensor. (Figure #21)

Figure #21





To adjust the pilot flame, remove the pilot adjustment cover screw (Figures #14 - #16 on previous pages) and turn the inner adjustment screw counterclockwise  to increase or clockwise  to decrease pilot flame. Be sure to replace cover screw after adjustment to prevent possible gas leakage.

The burners and pilot should be checked for signs of corrosion, rust or scale buildup. The area around the boiler must be kept clear and free of combustible materials, gasoline and other flammable vapors and liquids.

The free flow of combustion and ventilating air to the boiler and boiler room must not be restricted or blocked.

It is recommended that a qualified service agency be employed to make an annual inspection of the boiler and heating system. They are experienced in making the inspections outlined above, and, in the event repairs or corrections are necessary, trained technicians can make the proper changes for safe operation of the boiler.

CHECKING GAS INPUT RATE TO BOILER

Gas input to the boiler can be adjusted by removing the protective cap on the pressure regulator (**Figures #14-#16**) and turning the screw clockwise  to increase input and counterclockwise  to decrease input. The manifold pressures are taken at the outlet side of the gas valve. (**Figure #15 and #16**) To check for proper flow of natural gas to the boiler, divide the input rate shown on the rating plate by the heating value of the gas obtained from the local gas company. This will determine the number of cubic feet of gas required per hour. With all other gas appliances off, determine the flow of gas through the meter for two minutes and multiply by 30 to get the hourly rate. Make minor adjustments to the gas input as described above.

Burner orifices should be changed if the final manifold pressure varies more than plus or minus 0.3 inches water column from the specified pressure.

Primary air adjustment is not necessary, therefore air shutters are not furnished as standard equipment. Air shutters can be furnished on request where required by local codes or conditions.

CHECK SAFETY CONTROL CIRCUIT after burner adjustments are made for satisfactory operation.

1. Pilot: With main burner operating, turn the pilot gas adjusting screw clockwise  until pilot gas is turned off. (**Figures #14-#16** on previous pages) Within 90 seconds the main gas control should close, shutting off the gas to the main burner.

2. High Limit Control (Figure #22): Remove cover and note temperature setting. Decrease this setting to minimum and operate boiler. When the boiler water temperature exceeds the control temperature setting, the control will open the circuit, closing the automatic main gas valve.

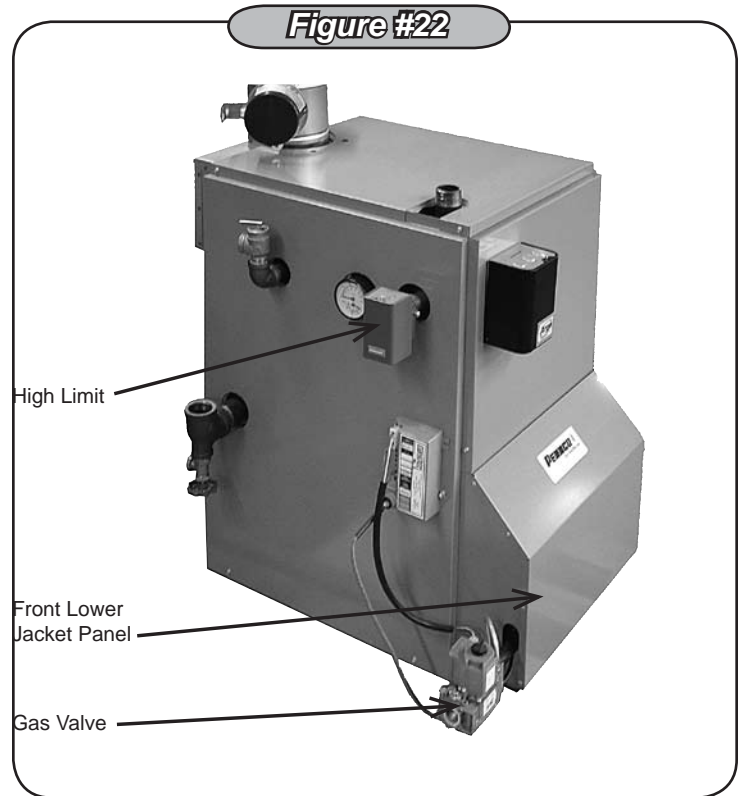

BOILER EXPLODED VIEW

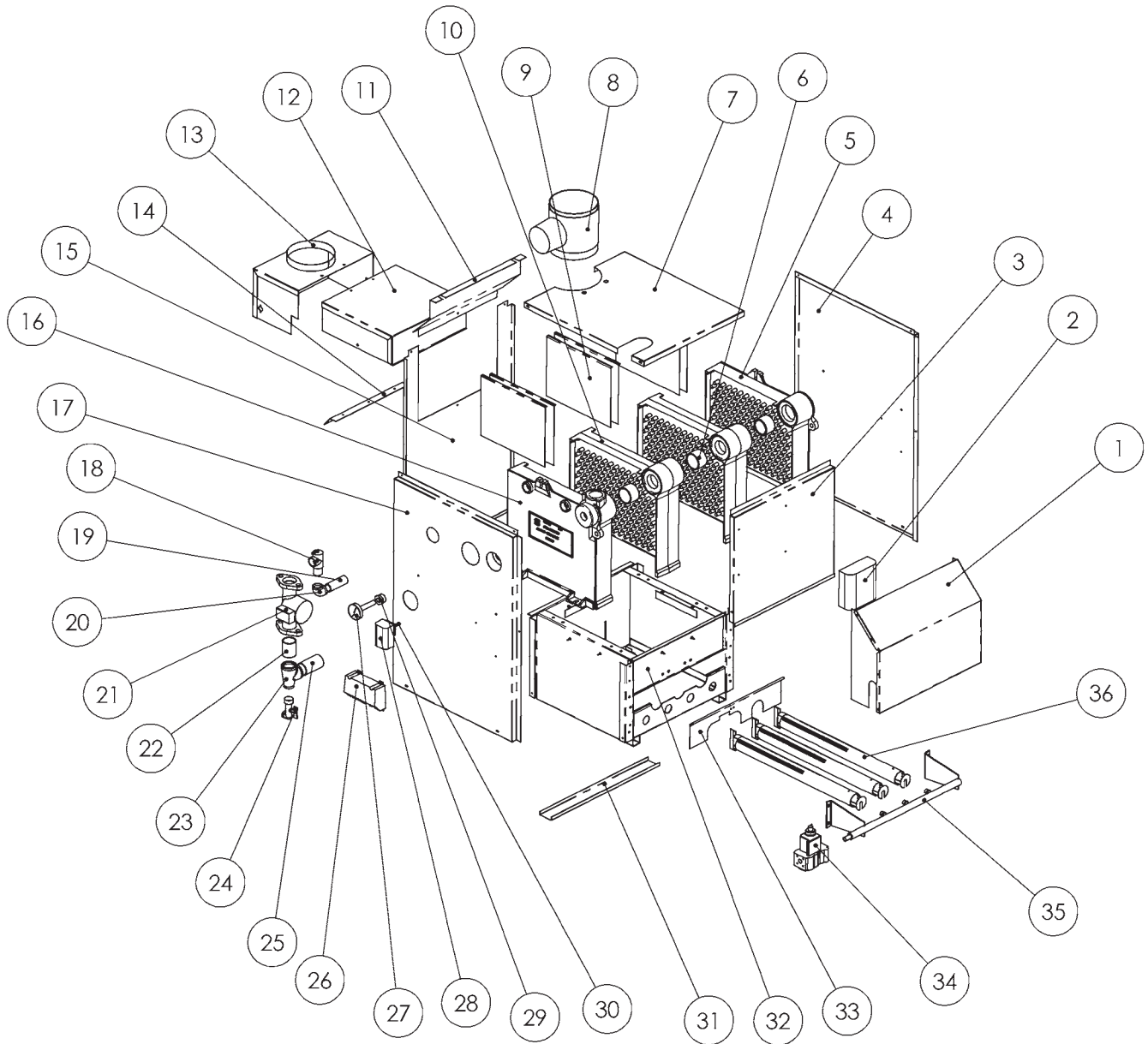

| Item | Description | Item | Description | Item | Description |
|------|---------------------|------|-------------------|------|---------------------|
| 1 | Jacket Front Lower | 13 | Draft Hood | 25 | Pipe Nipple |
| 2 | Control | 14 | Restrictor | 26 | Pilot Spark Control |
| 3 | Jacket Front Upper | 15 | Jacket Back | 27 | Theraltimeter Gauge |
| 4 | Jacket Side Right | 16 | Right End Section | 28 | High Limit Control |
| 5 | Left End Section | 17 | Jacket Side Left | 29 | Pipe Bushing |
| 6 | Push Nipple | 18 | Relief Valve | 30 | Well |
| 7 | Jacket Top | 19 | Pipe Nipple | 31 | Tray |
| 8 | Damper | 20 | Pipe Elbow | 32 | Base |
| 9 | Baffle | 21 | Circulator | 33 | Burner Door |
| 10 | Center Section | 22 | Pipe Nipple | 34 | Gas Valve |
| 11 | Jacket Back To Flue | 23 | Pipe Tee | 35 | Manifold |
| 12 | Flue Collector | 24 | Drain Cock | 36 | Burner Tube |

REPLACEMENT PARTS - BASE

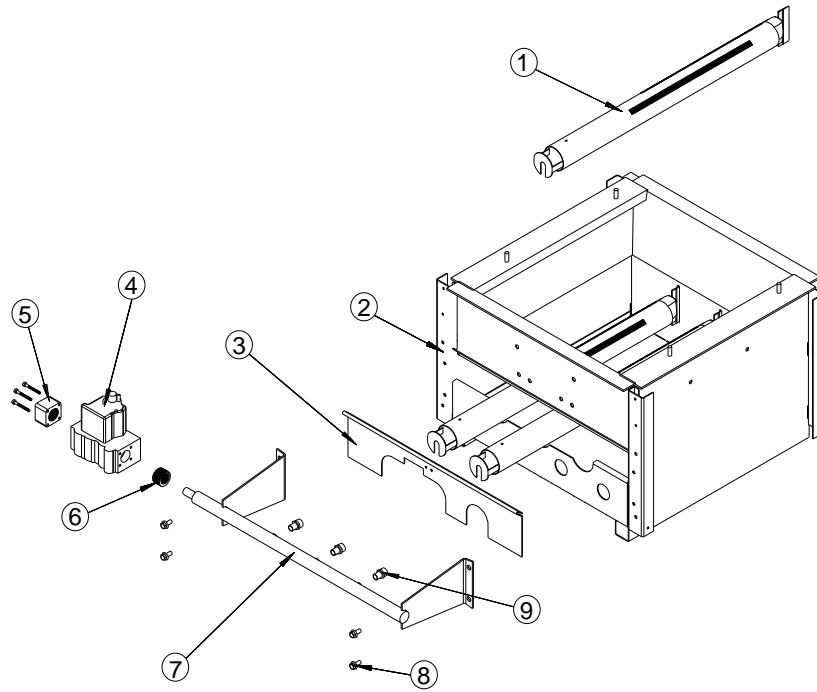

| Item | Part No. | Description | QTY. |
|------|------------|---|------|
| 1 | 240005543 | Burner Tube 1½" (045) | 1 |
| | | Burner Tube 1½" (070, 096) | 2 |
| | | Burner Tube 1½" (120, 145) | 3 |
| | | Burner Tube 1½" (175, 195) | 4 |
| | | Burner Tube 1½" (245) | 5 |
| | | Burner Tube 1½" (295) | 6 |
| 2 | 5611601 | Base w/Insul & Bracket (045) | 1 |
| | 5611602 | Base w/Insul & Bracket (070, 096) | |
| | 5611603 | Base w/Insul & Bracket (120, 145) | |
| | 5611604 | Base w/Insul & Bracket (175, 195) | |
| | 5611605 | Base w/Insul & Bracket (245) | |
| | 5611606 | Base w/Insul & Bracket (295) | |
| 3 | 3261201 | Burner Door (045) | 1 |
| | 32611405 | Burner Door (070, 096) | |
| | 32611401 | Burner Door (120, 145) | |
| | 32611402 | Burner Door (175, 195) | |
| | 32611403 | Burner Door (245) | |
| | 32611404 | Burner Door (295) | |
| 4 | VG-003.05 | Gas Valve, 24V Nat (045-145) | 1 |
| | VG00307 | Gas Valve, 24V LP (045-295) | |
| | VG01101 | Gas Valve, Spark Nat (045-145) | |
| | VG01103 | Gas Valve, Spark Nat (175-295) | |
| | VG01104 | Gas Valve, Spark LP (045-295) | |
| | VG01201 | Gas Valve, 24V Nat (245, 295) | |
| | VG01202 | Gas Valve, 24V Nat (175, 195) | |
| 5 | VG01601 | Straight Flange - ¾" NPT (175, 195, 245, 295 - LP ONLY) | 1 |
| 6 | VG-006.00 | Internal Bushing ¾ x ½ (ALL LP) | 1 |
| 7 | 356-2-1.01 | Manifold (045) | 1 |
| | 356-2-1.02 | Manifold (070, 096) | |

| Item | Part No. | Description | Qty. |
|-----------------------|-----------------------|--------------------------------------|------|
| 7 | 356-2-1.03 | Manifold (120, 145) | 1 |
| | 356-2-1.04 | Manifold (175, 195) | |
| | 356-2-1.05 | Manifold (245) | |
| | 356-2-1.06 | Manifold (295) | |
| 8 | HW-005.01 | Screw ¼ - 20 x ½ Self Tap | 4 |
| 9 | 240007406 | Orifice 3.2mm, Nat. (096) | 2 |
| | | Orifice 3.2mm, Nat. (145) | 3 |
| | | Orifice 3.2mm Nat. (195) | 4 |
| | | Orifice 3.2mm, Nat. (245) | 5 |
| | | Orifice 3.2mm, Nat. (295) | 6 |
| | 240007405 | Orifice 3.1mm, Nat (045) | 1 |
| | 240007404 | Orifice 3.0mm, Nat (175) | 4 |
| | 240007403 | Orifice 2.9mm, Nat (120) | 3 |
| | 240007402 | Orifice 2.8mm, Nat (070) | 2 |
| | 355-1-5.04 | Orifice #47, LP (045) | 1 |
| | | Orifice #47, LP (096) | 2 |
| | | Orifice #47, LP (145) | 3 |
| | | Orifice #47, LP (195) | 4 |
| | | Orifice #47, LP (245) | 5 |
| Orifice #47, LP (295) | | 6 | |
| 355-1-5.06 | Orifice #49, LP (120) | 3 | |
| | Orifice #49, LP (175) | 4 | |
| 355-1-5.07 | Orifice #50, LP (070) | 2 | |
| NOT SHOWN | 325-2-8.01 | Combustible Base Flooring - 45 | 1 |
| | 325-2-8.02 | Combustible Base Flooring - 70, 96 | |
| | 325-2-8.03 | Combustible Base Flooring - 120, 145 | |
| | 325-2-8.04 | Combustible Base Flooring - 175, 195 | |
| | 325-2-8.05 | Combustible Base Flooring - 245 | |
| | 325-2-8.06 | Combustible Base Flooring - 295 | |

REPLACEMENT PARTS - HEAT EXCHANGER

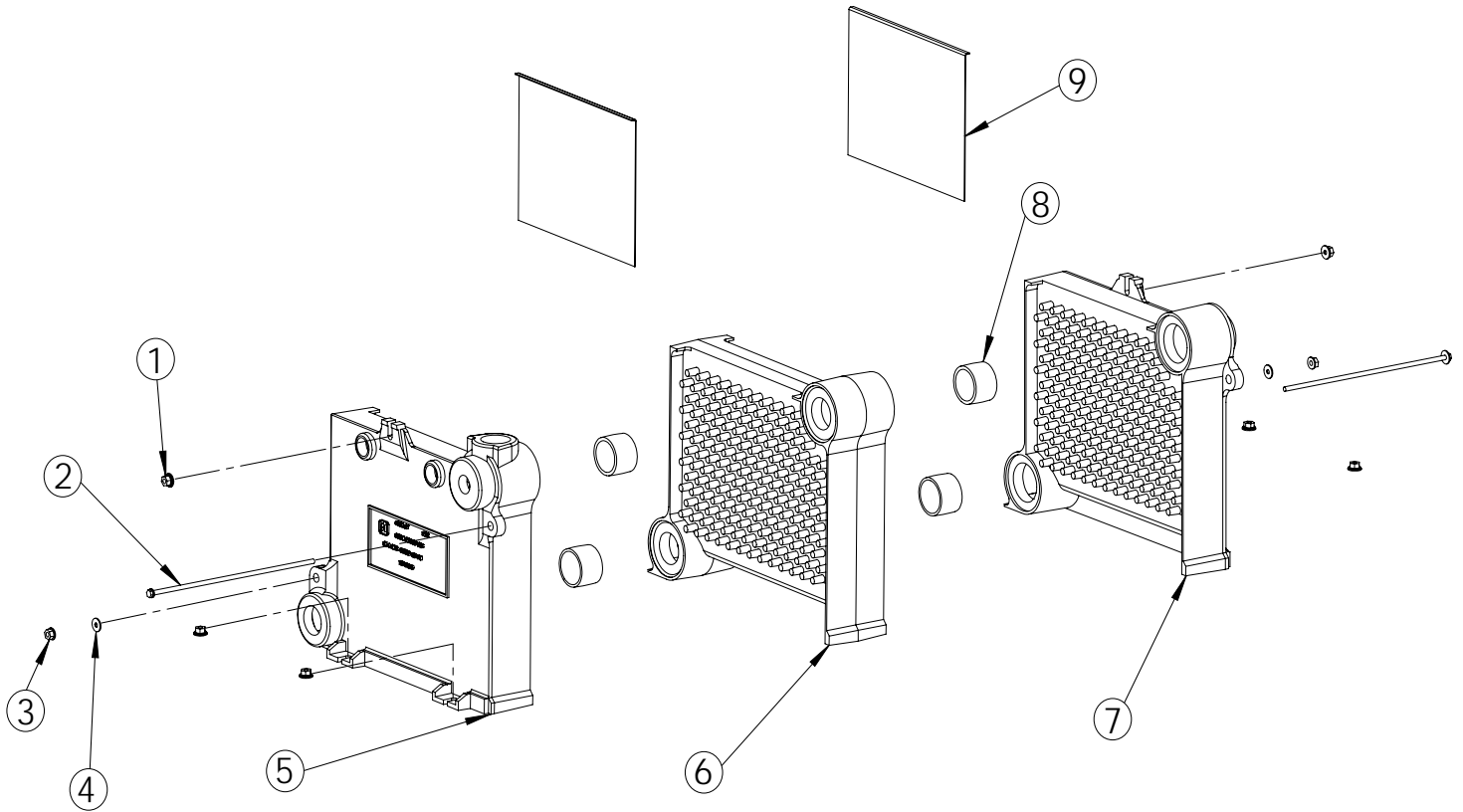

| Item | Part No. | Description | Qty. |
|------|------------|--|------|
| 1 | HW06901 | Nut $\frac{5}{16}$ - 18 Wislock | 6 |
| 2 | 14605001 | Tie Rod - $\frac{1}{4}$ " x $7\frac{1}{4}$ " (045) | 2 |
| | HW-011.01 | Tie Rod - $\frac{1}{4}$ " x $11\frac{1}{2}$ " (070, 096) | |
| | HW-011.03 | Tie Rod - $\frac{1}{4}$ " x $15\frac{1}{2}$ " (120, 145) | |
| | HW-011.05 | Tie Rod - $\frac{1}{4}$ " x $19\frac{1}{2}$ " (175, 195) | |
| | HW-011.07 | Tie Rod - $\frac{1}{4}$ " x 23" (245) | |
| | HW-011.09 | Tie Rod - $\frac{1}{4}$ " x 27" (295) | |
| 3 | HW-003.02 | Nut $\frac{1}{4}$ "-20 Hex | 2 |
| 4 | HW-008.01 | Washer - $\frac{5}{16}$ " Flat | 4 |
| 5 | 100-2-3.01 | B - Right Hand Section | 1 |
| 6 | 100-2-1.01 | B - Center Section (070, 096) | 1 |
| | | B - Center Section (120, 145) | 2 |
| | | B - Center Section (175, 195) | 3 |
| | | B - Center Section (245) | 4 |
| | | B - Center Section (295) | 6 |

| Item | Part No. | Description | Qty. |
|--|------------|---------------------------------|------|
| 7 | 100-2-2.01 | B - Left Hand Section | 1 |
| 8 | 43300976 | Push Nipple 2" Mach. (045) | 2 |
| | | Push Nipple 2" Mach. (070, 096) | 4 |
| | | Push Nipple 2" Mach. (120, 145) | 6 |
| | | Push Nipple 2" Mach. (175, 195) | 8 |
| | | Push Nipple 2" Mach. (245) | 10 |
| | | Push Nipple 2" Mach. (295) | 12 |
| 9 | 3461601 | Baffle (045 Only) | 2 |
| Fully Assembled Heat Exchangers | | | |
| | 100-2-7.01 | Heat Exchanger (3 Section) | |
| | 100-2-7.02 | Heat Exchanger (4 Section) | |
| | 100-2-7.03 | Heat Exchanger (5 Section) | |
| | 100-2-7.04 | Heat Exchanger (6 Section) | |
| | 100-2-7.05 | Heat Exchanger (7 Section) | |
| | 100-2-7.06 | Heat Exchanger (2 Section) | |

REPLACEMENT PARTS - JACKET

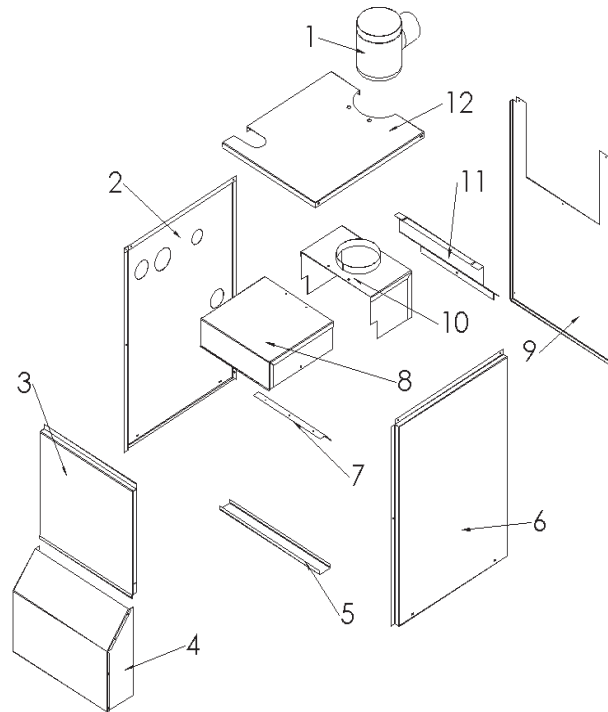

| Item | Part No. | Description | Qty. |
|------|-----------|---------------------------------|------|
| 1 | 240006936 | 4" Damper (045) | 1 |
| | 240006937 | 5" Damper (070, 096) | |
| | 240006938 | 6" Damper (120, 145) | |
| | 240006939 | 7" Damper (175, 195) | |
| | 240006940 | 8" Damper (245) | |
| | 240006941 | 9" Damper (295) | |
| 2 | 31623101 | Jkt Side Left Panel (046-295) | 1 |
| 3 | 31623001 | Jkt Front Upper (045) | 1 |
| | 31623002 | Jkt Front Upper (070, 096) | |
| | 31623003 | Jkt Front Upper (120, 145) | |
| | 31623004 | Jkt Front Upper (175, 195) | |
| | 31623005 | Jkt Front Upper (245) | |
| | 31623006 | Jkt Front Upper (295) | |
| 4 | 31622001 | Jkt Front Lower (045) | 1 |
| | 31622002 | Jkt Front Lower (070, 096) | |
| | 31622003 | Jkt Front Lower (120, 145) | |
| | 31622004 | Jkt Front Lower (175, 195) | |
| | 31622005 | Jkt Front Lower (245) | |
| | 31622006 | Jkt Front Lower (295) | |
| 5 | 31622701 | Tray (045) | 1 |
| | 31622702 | Tray (070, 096) | |
| | 31622703 | Tray (120, 145) | |
| | 31622704 | Tray (175, 195) | |
| | 31622705 | Tray (245) | |
| | 31622706 | Tray (295) | |
| 6 | 31623201 | Jkt Side Right Panel (046-295) | 1 |
| 7 | 3461701 | Flue Collector Restrictor (045) | 1 |
| | 3461702 | Flue Collector Restrictor (070) | |
| | 3461703 | Flue Collector Restrictor (096) | |
| | 3461704 | Flue Collector Restrictor (295) | |

| Item | Part No. | Description | Qty. |
|------|----------|-----------------------------|------|
| 8 | 34620501 | Flue Collector (045) | 1 |
| | 34620502 | Flue Collector (070, 096) | |
| | 34620503 | Flue Collector (120, 145) | |
| | 34620504 | Flue Collector (175, 195) | |
| | 34620505 | Flue Collector (245) | |
| | 34620506 | Flue Collector (295) | |
| 9 | 31623301 | Jkt Back Panel (045) | 1 |
| | 31623302 | Jkt Back Panel (070, 096) | |
| | 31623303 | Jkt Back Panel (120, 145) | |
| | 31623304 | Jkt Back Panel (175, 195) | |
| | 31623305 | Jkt Back Panel(245) | |
| | 31623306 | Jkt Back Panel (295) | |
| 10 | 34620601 | Draft Hood (045) | 1 |
| | 34620602 | Draft Hood (070, 096) | |
| | 34620603 | Draft Hood (120, 145) | |
| | 34620604 | Draft Hood (175, 195) | |
| | 34620605 | Draft Hood (245) | |
| | 34620606 | Draft Hood (295) | |
| 11 | 31623501 | Jkt Back to Flue (045) | 1 |
| | 31623502 | Jkt Back to Flue (070, 096) | |
| | 31623503 | Jkt Back to Flue (120, 145) | |
| | 31623504 | Jkt Back to Flue (175, 195) | |
| | 31623505 | Jkt Back to Flue (245) | |
| | 31623506 | Jkt Back to Flue (295) | |
| 12 | 31622901 | Jkt Top Panel (045) | 1 |
| | 31622902 | Jkt Top Panel (070, 096) | |
| | 31622903 | Jkt Top Panel (120, 145) | |
| | 31622904 | Jkt Top Panel (175, 195) | |
| | 31622905 | Jkt Top Panel (245) | |
| | 31622906 | Jkt Top Panel (295) | |

REPLACEMENT PARTS - PILOT

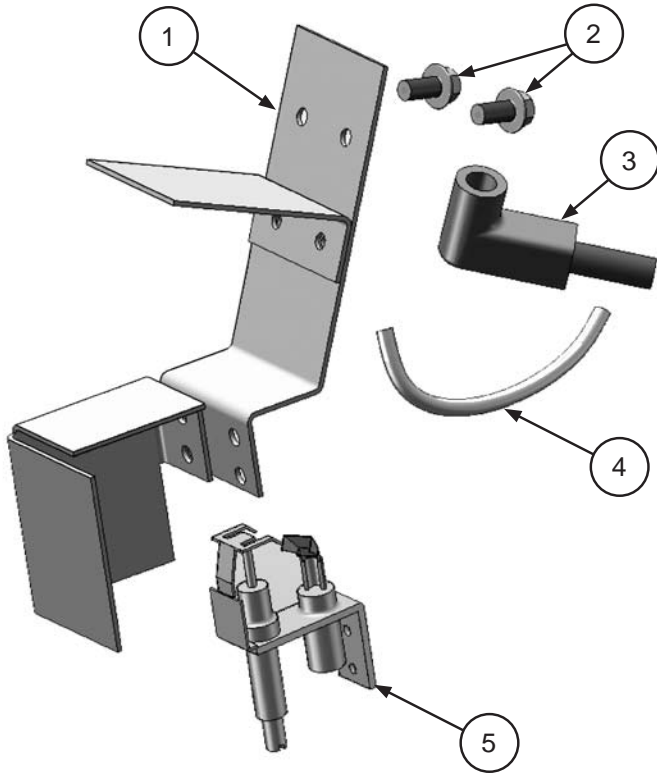

| SPARK PILOT | | | |
|-------------|-----------|--------------------------|------|
| Item | Part No. | Description | Qty. |
| 1 | 109007296 | PILOT BRACKET ASSEMBLY | 1 |
| 2 | HW-005.01 | BRACKET SCREW | 2 |
| 3 | 240007093 | SPARK CABLE | 1 |
| 4 | 14615005 | PILOT TUBING, 1/8" x 24" | 1 |
| 5 | PB-001.02 | Natural Gas Q345A PILOT | 1 |
| | 240007096 | LP Q345A Pilot | |

* Included with #3 - Pilot Tube Assembly Kit (above)

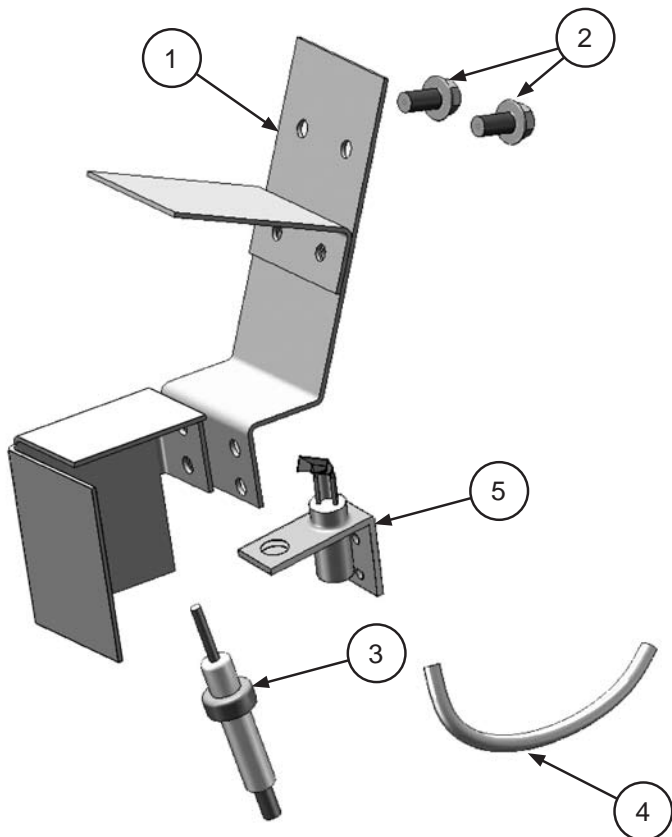

| CONTINUOUS PILOT | | | |
|------------------|-----------|--------------------------|------|
| Item | Part No. | Description | Qty. |
| 1 | 109007296 | PILOT BRACKET ASSEMBLY | 1 |
| 2 | HW-005.01 | BRACKET SCREW | 2 |
| 3 | 1520001 | THERMOCOUPLE Q309 | 1 |
| 4 | 14615005 | PILOT TUBING, 1/8" x 24" | 1 |
| 5 | 14662098 | Natural Gas Q314A PILOT | 1 |
| | 240007285 | LP Q314A Pilot | |

* Included with #3 - Pilot Tube Assembly Kit (above)

REPLACEMENT PARTS - PIPING & CONTROLS

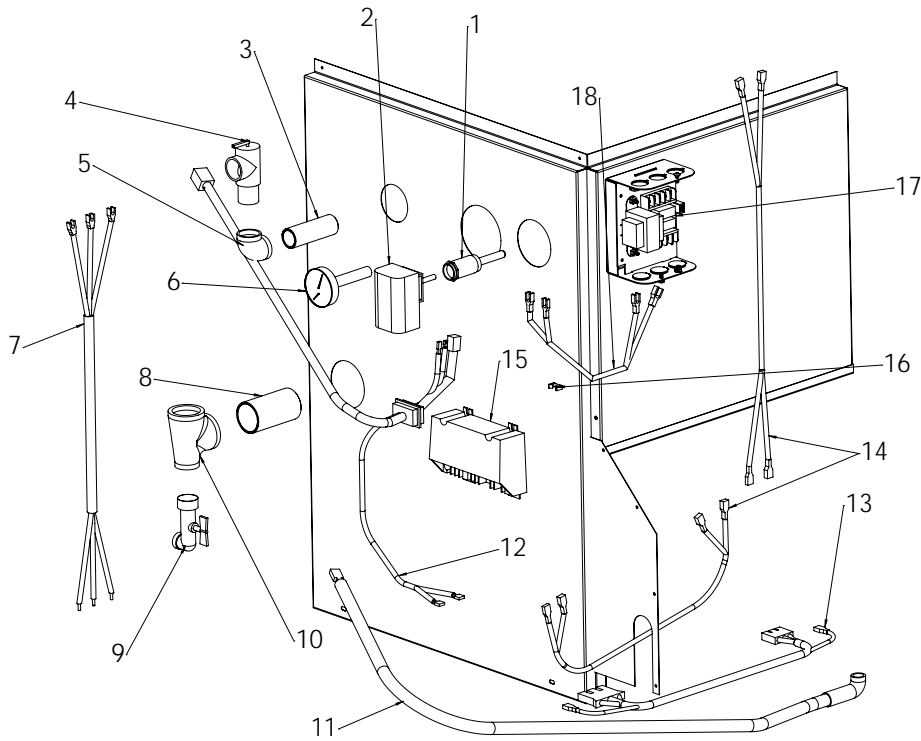

| Item | Part No. | Description | Qty. |
|------|-----------|-----------------------------|------|
| 1 | AQ-020.01 | Well ¾" x 3" | 1 |
| 2 | AQ02201 | High Limit Control | 1 |
| 3 | 1310001 | Pipe - Nipple ¾" x 4" | 1 |
| 4 | VR-001.01 | Relief Valve 30# | 1 |
| 5 | 1190001 | Pipe - Elbow ¾" 90° | 1 |
| 6 | 1260006 | Gauge - Theraltimeter | 1 |
| 7 | 37519501 | Harness Circulator 72" | 1 |
| 8 | 1310002 | Pipe - Nipple 1¼" x 4½" NPT | 1 |
| 9 | HW-016.03 | Drain Valve | 1 |

| Item | Part No. | Description | Qty. |
|------|-------------|-------------------------------------|------|
| 10 | 1516001 | Pipe - Tee 1¼" x ¾" x 1¼" | 1 |
| 11 | 240007093 | Pilot Ignition Cable 30" | 1 |
| 12 | 375-1-14.01 | Wire - Low Voltage/Damper | 1 |
| 13 | 37413602 | Harness - Ignition to Gas Valve 18" | 1 |
| 14 | 37513301 | Wire - Rollout/Spill 28" | 2 |
| 15 | 14662070 | Pilot Spark Control | 1 |
| 16 | EF03601 | Clamp #3600 White | 2 |
| 17 | Z99 | Control Vent Damper | 1 |
| 18 | 240004779 | Wire, 2 Cond., Bonded 18" | 1 |

REPLACEMENT PARTS - ROLLOUT & SPILL SWITCH

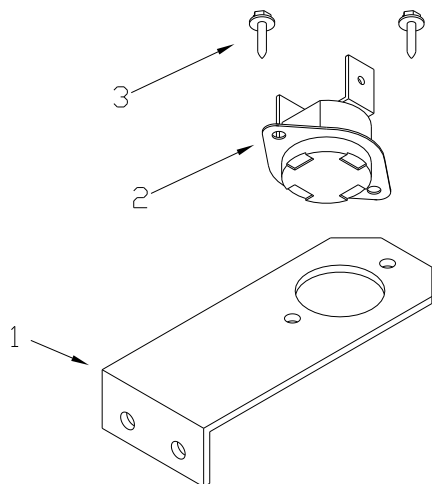

| ITEM | PART NO. | DESCRIPTION | QTY.* |
|------|----------|---|-------|
| 1a | 32611001 | Temp. Sensor Bracket - Base | 1 |
| 1b | 3461201 | Temp. Sensor Bracket - Flue Collector | 1 |
| 2 | AQ02101 | Control - Fixed Temperature Thermostat (Rollout Switch) | 1 |
| 3 | HW06501 | Screw - #6 x 1/4" Hex HD | 2 |

NOTES:

- (1) The rollout switch is located on the manifold bracket.
- (2) The quantities above are for each switch.

CONVERSION KITS

| LP TO NATURAL GAS | | |
|-------------------|-----------|--------------------------------|
| Model | Part No. | Description |
| 15B045 | 550001270 | Kit, Conversion, LP to Natural |
| 15B070 | 550001271 | Kit, Conversion, LP to Natural |
| 15B096 | 550001272 | Kit, Conversion, LP to Natural |
| 15B120 | 550001273 | Kit, Conversion, LP to Natural |
| 15B145 | 550001274 | Kit, Conversion, LP to Natural |
| 15B175 | 550001275 | Kit, Conversion, LP to Natural |
| 15B195 | 550001276 | Kit, Conversion, LP to Natural |
| 15B245 | 550001277 | Kit, Conversion, LP to Natural |
| 15B295 | 550001278 | Kit, Conversion, LP to Natural |

| NATURAL GAS TO LP | | |
|-------------------|-----------|--------------------------------|
| Model | Part No. | Description |
| 15B045 | 550001279 | Kit, Conversion, Natural to LP |
| 15B070 | 550001280 | Kit, Conversion, Natural to LP |
| 15B096 | 550001281 | Kit, Conversion, Natural to LP |
| 15B120 | 550001282 | Kit, Conversion, Natural to LP |
| 15B145 | 550001283 | Kit, Conversion, Natural to LP |
| 15B175 | 550001284 | Kit, Conversion, Natural to LP |
| 15B195 | 550001285 | Kit, Conversion, Natural to LP |
| 15B245 | 550001286 | Kit, Conversion, Natural to LP |
| 15B295 | 550001287 | Kit, Conversion, Natural to LP |



85 Middle Rd.
Dunkirk, NY 14048