

Residential Steam Boilers



KSC IV Series

Oil-Fired Steam Boiler



Heat Shield Baffle

Standard Equipment:

- Crated Cast-Iron Boiler
- Flush Jacket
- Swing-Out Burner Door
- Beckett Oil Burner
- Target Wall/Liner
- Honeywell Pressure Control
- Boiler Water Level Gauge Glass
- Steam Pressure Gauge
- Electronic Low Water Cut-Off
- ASME Relief Valve
- Drain Valve
- Wiring Harness
- Burner Electric Disconnect
- Supply Tapping (2")
- Return Tapping – 1½"
- Skim Port

Tankless Water Heater Option:

- Tankless Hot Water Coil

The Pennco KSC IV Series features a patented protective heat shield baffle to protect the casting above the water line.

Quality Heat Exchanger Design – The KSC IV Series features a robust cast iron heat exchanger for longer boiler life. The sections are connected with cast iron push nipples, which expand and contract at the same rate as the sections ensuring a water tight seal. The KSC IV Series is available in four sizes from 106 MBH to 247 MBH.

Efficiency – The KSC IV Series provides an EnergyStar rated annual fuel utilization efficiency of 82% as certified by the US Department of Energy testing standards.

Warranty – The Pennco KSC IV comes with a Limited 10 Year Manufacturer's Warranty.

Built by American Craftsmen.

Pennco SILVER makes **Simple Comfort, Affordable.**

KSC IV Series

Oil-Fired Steam Boiler

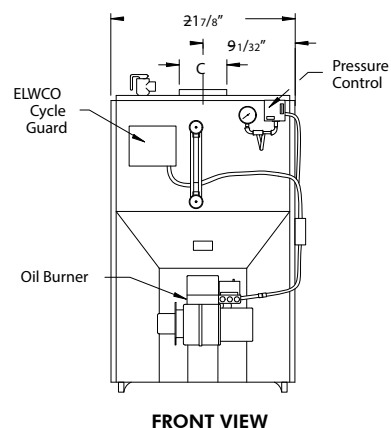
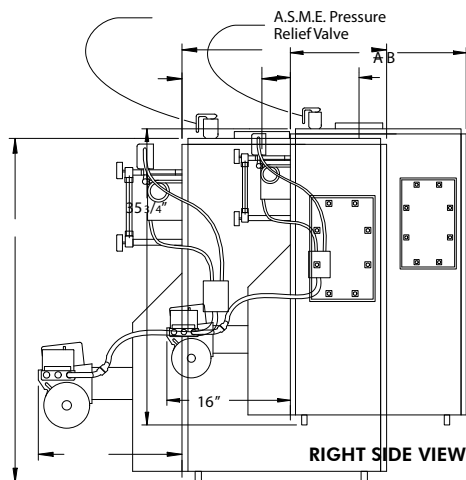

Specifications:

Model	AHRI Oil Burner Input ⁽¹⁾		Htg. Cap. MBH ⁽⁴⁾	Net AHRI Ratings ⁽³⁾		Min. Nat. Draft Chimney Size		Pump Press. PSI	Nozz. Furn.	AFUE % ⁽⁴⁾
	G.H.	MBH ⁽²⁾		Steam	Sq. Ft. MBH Steam	Round	Square			
WITHOUT TANKLESS										
KSC-3090S	0.90	126	106	80	333	6"	8"x8"x15'	150	0.75-60°B	82.0%
KSC-4125S	1.25	175	147	110	458	6"	8"x8"x15'	140	1.10-60°B	82.0%
KSC-5185S	1.85	259	216	162	675	8"	8"x8"x15'	150	1.50-70°B	82.0%
KSC-6210S	2.10	294	247	185	771	8"	8"x8"x15'	145	1.75-70°B	82.0%
WITH TANKLESS										
KSC-3090ST	0.90	126	106	80	333	6"	8"x8"x15'	150	0.75-60°B	82.0%
KSC-4125ST	1.25	175	147	110	458	6"	8"x8"x15'	140	1.10-60°B	82.0%
KSC-5185ST	1.85	259	216	162	675	8"	8"x8"x15'	150	1.50-70°B	82.0%
KSC-6210ST	2.10	294	247	185	771	8"	8"x8"x15'	145	1.75-70°B	82.0%

(1) Burner input is based on an oil heating value of 140,000 Btu/gal.

(2) MBH = 1000 Btu per hour [Btu = British Thermal Unit].

(3) Net AHRI Steam Ratings based on piping and pick-up allowance of 1.333. Consult manufacturer before selecting boiler for installations having unusual piping and pick-up requirements, such as intermittent system operation, extensive piping, etc.

(4) Heating Capacity and AFUE based on 13.0% CO₂ with -0.02" W.C. draft over fire and #1 smoke or less. Tested in accordance with U.S. Department of Energy



ECR International Inc. 2 2201 Dwyer Avenue, Utica, NY
13501 Tel. 800 253 7900
www.ecrinternational.com

All specifications subject to change without notice.
©2017 ECR International, Inc.
PN 240009897 REV. [10/2017]